

**GENERAL INFORMATION:**

**BASIC DATA (PER CELL):**  
 MIN/MAX GPM RANGE - 200/600  
 ACTUAL DESIGN GPM - -  
 HWT(°F) - -  
 CWT(°F) - -  
 WBT(°F) - -

**MOTOR DATA:**  
 BRAND - U.S. MOTORS (OR EQUIV)  
 EFFICIENCY - HIGH  
 HP - 7.5  
 VOLTAGE - 460  
 HZ - 60  
 PHASE - 3  
 NUMBER - 2

**WEIGHTS (PER CELL):**  
 DRY SHIPPING WEIGHT - 5,000 lbs  
 OPERATING WEIGHT - 8,500 lbs

1. ALL EXTERNAL PIPING PROVIDED BY CUSTOMER.
2. EXTERNAL PIPING TO BE "STAND ALONE" (INDEPENDENTLY SUPPORTED).
3. NO LOAD TO BE APPLIED TO TOWER TECH TOWER OR SUMP.
4. FOR APPROPRIATE WATER LEVEL REFER TO STARTUP SECTION IN TOWER TECH'S DESIGN, INSTALLATION & OPERATION MANUAL.

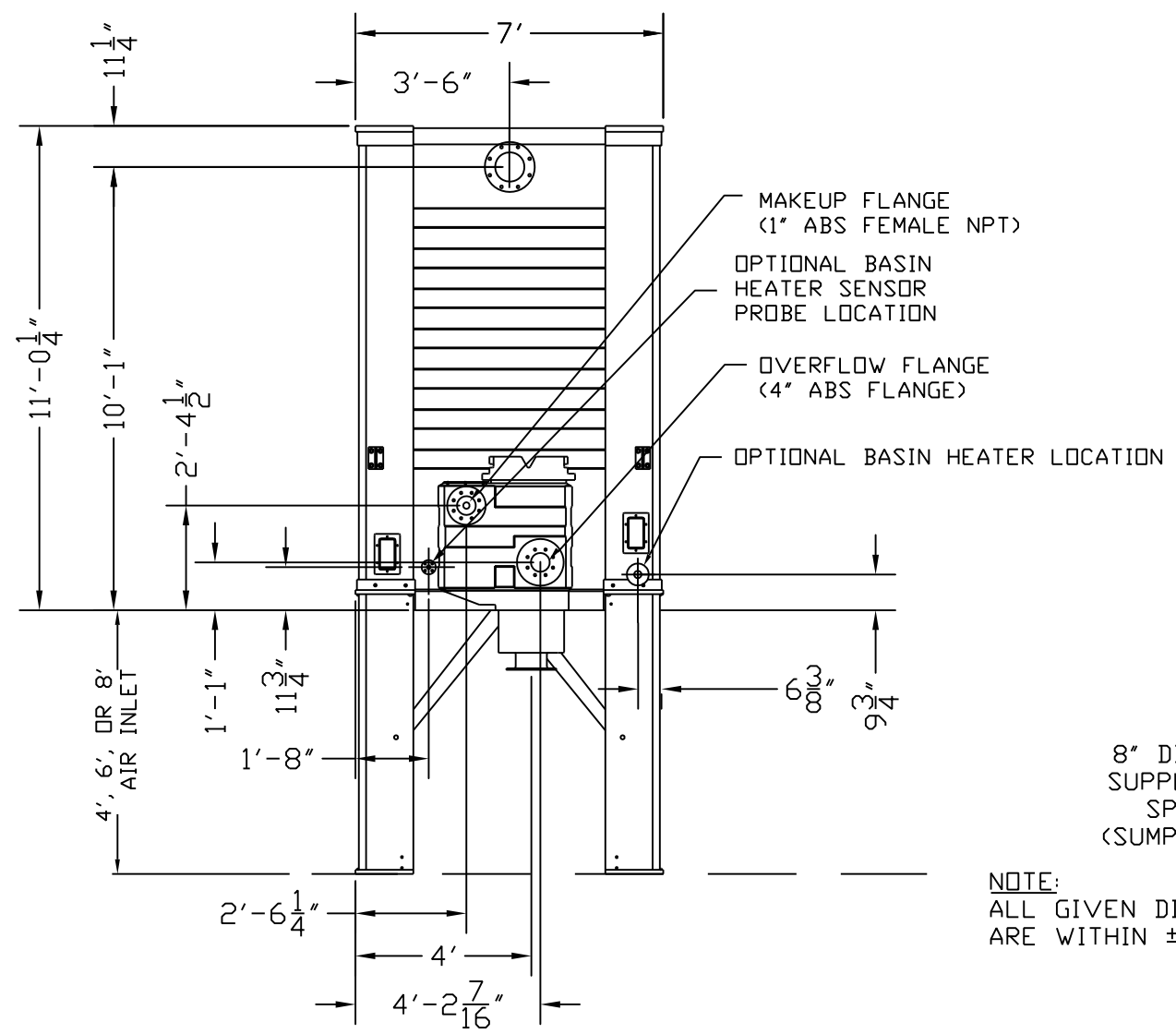

NOTE:  
 ALL GIVEN DIMENSIONS ARE WITHIN ±1/2"

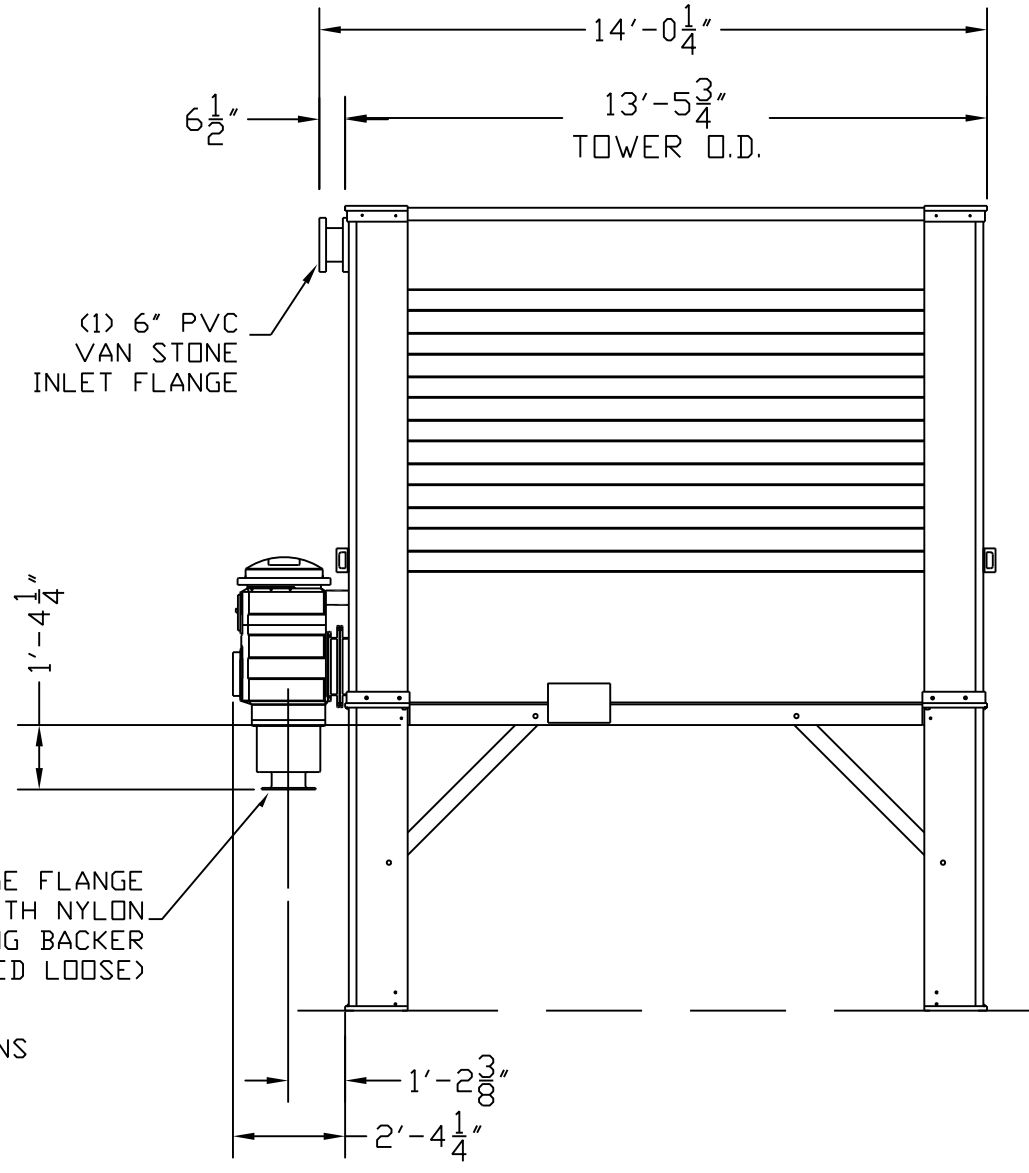

**TOWER TECH, Inc.**  
 THE TECHNOLOGY COMPANY

TELEPHONE: (405) 290-7788  
 FAX: (405) 979-2131  
 E-MAIL: [cod@towertechinc.com](mailto:cod@towertechinc.com)  
 WEBPAGE: <http://www.towertechinc.com>  
 5400 NW 5th  
 OKLAHOMA CITY, OKLAHOMA 73127

Modular  
 Fiberglass  
 Cooling Tower  
 Model # TTXL-021975

© 2001-2008 BY TOWER TECH, INC.  
 ALL RIGHTS RESERVED

**TOWER TECH, INC.**  
**1-Unit Installation**  
**TTXL-02 Plan & Elevation**

Oklahoma City, Oklahoma

FOR APPROVAL BY	DATE
Tower Tech Design Team	
REVISIONS	
NO.	DATE

DATE:	22 FEB 08
DRAWING#:	XL-02-2
PROJECT#:	LIBRARY
CUST PO#:	
DRAWN BY:	RFB
CHECKED BY:	
PLAN & ELEVATION	2