

TTXL SERIES

Technical Reference Guide

FILL MEDIA

DIST
DRIP
SU

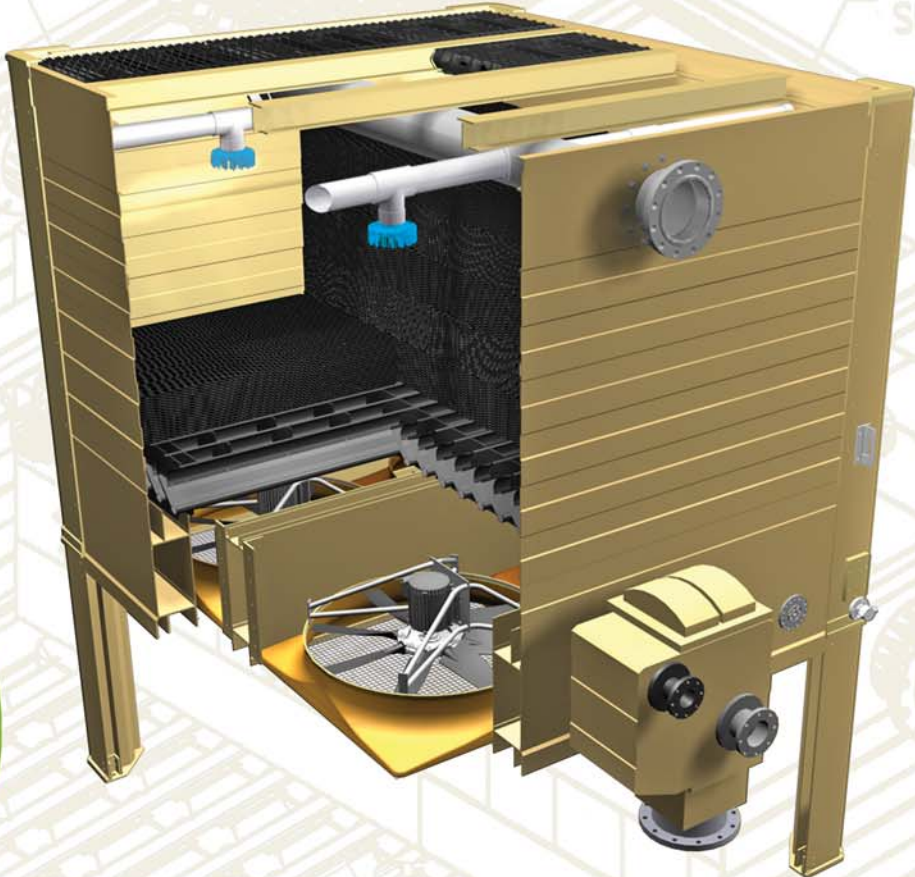

TOWER TECH
Outperform™

PERIMETER
FLOW-THRU BASIN™

SUMP DISCHARGE

TTXL SERIES

FEATURES:

The TTXL Series forced-draft, counter-flow cooling tower delivers reliable thermal performance in both constant and variable heat load applications. Its modular design enables easy interconnectability to create virtually any size cooling tower and quickly accommodates future expansion of cooling tower capacity.

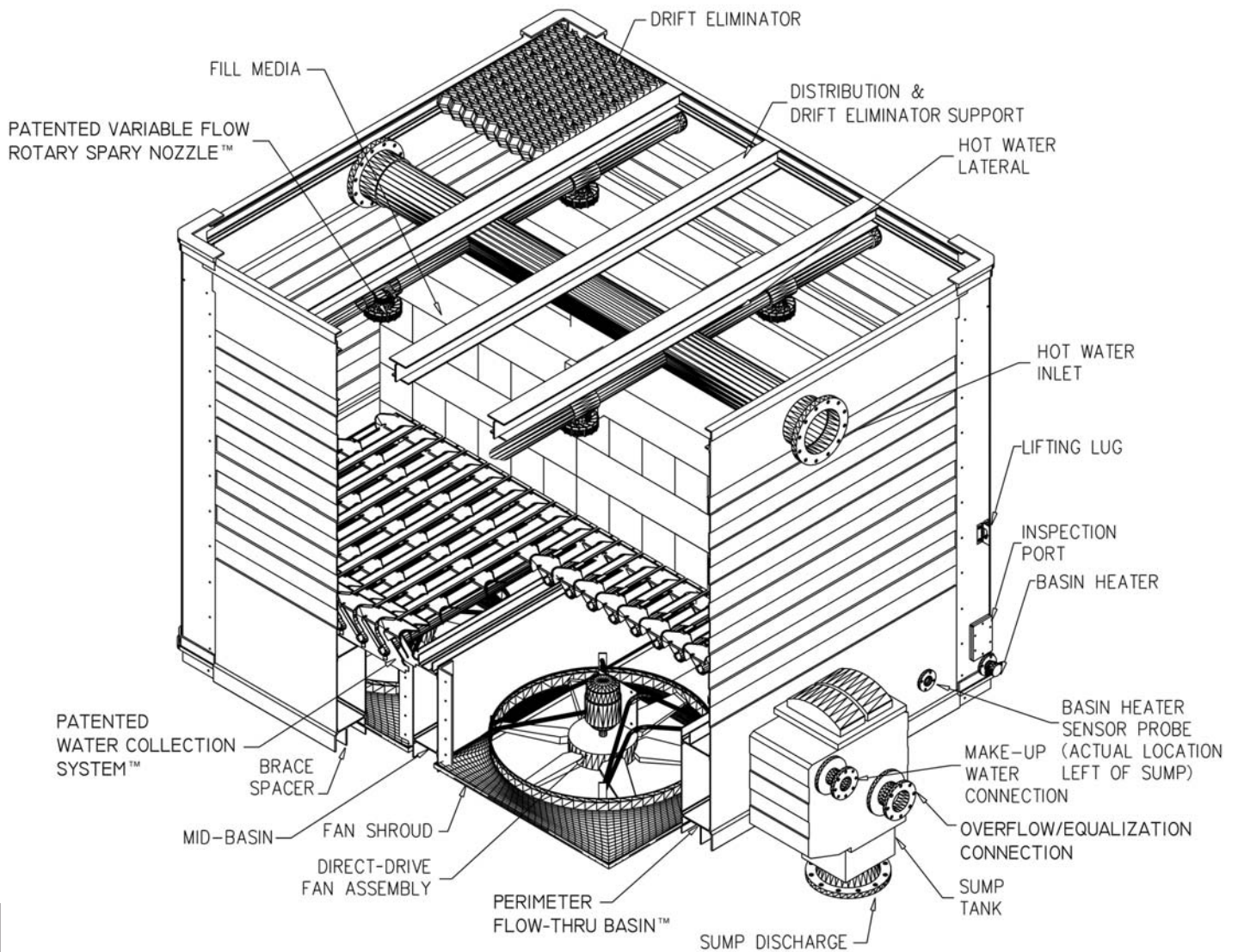

Unique Design Features Include:

- Fully Enclosed Flow-Thru Basin
- Variable-Flow Rotary Spray Nozzle
- Water Collection System
- Bottom Mounted Fans

Water Collection System™

TTXL's patented Water Collection System serves as an efficient collection chamber and conduit for channeling waterflow into the tower's Flow-Thru Basin™. Its unique shape aerodynamically moves inlet air into the fill media while effectively providing a leak free barrier protecting tower mechanicals.

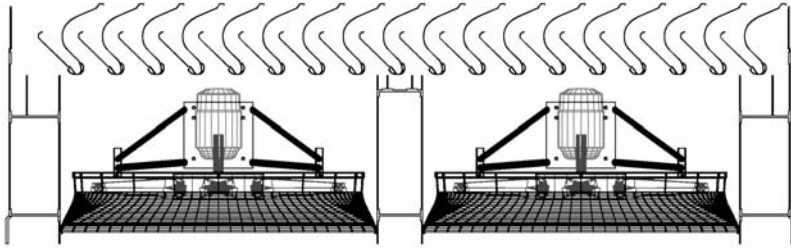

Flow-Thru Basin™

Unlike the low velocity cold-water settling basins common to conventional cooling tower designs, the TTXL tower incorporates a patented perimeter box beam which uniquely serves as both the cold water reservoir and provides the base structural component of the module. High water velocities in the basin beams continually scrub the walls and floor of the basin to eliminate the build-up of sediment and potentially bio-hazardous material – a common problem in conventional designs. Four access ports are provided for easy inspection.

Variable-Flow Rotary Spray Nozzle™

The patented Variable-Flow Rotary Spray Nozzle™ delivers even fill coverage across a broad range of system flows from 100 to 300 gpm per nozzle (6.5 -19.5 lps) at low pressures from .5 to 1.5 psi (3.45 to 10.3 kPa). The nozzle requires less pressure to operate than a conventional nozzle, is virtually maintenance free, and dramatically improves tower performance.

Use of a lateral spray pattern allows the nozzle to be positioned just one inch off the fill material, saving several feet of pump head. The nozzle's turbine-driven rotor spins on a water bearing that keeps the nozzle parts from wearing, as well as provides the needed agitation to ensure virtually clog-free service. The rotary turbine produces a larger water droplet than conventional nozzles and thereby reduces drift loading on the drift eliminators for the lowest drift loss coefficient of any cooling tower.

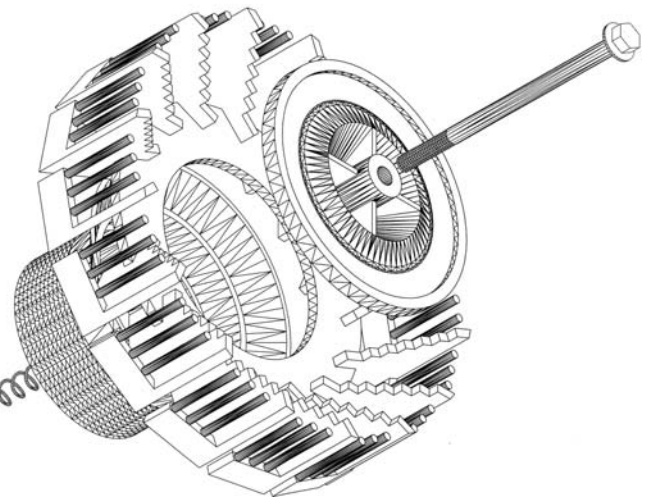

NOZZLE SPRAY DISTANCE
VERSUS FLOW

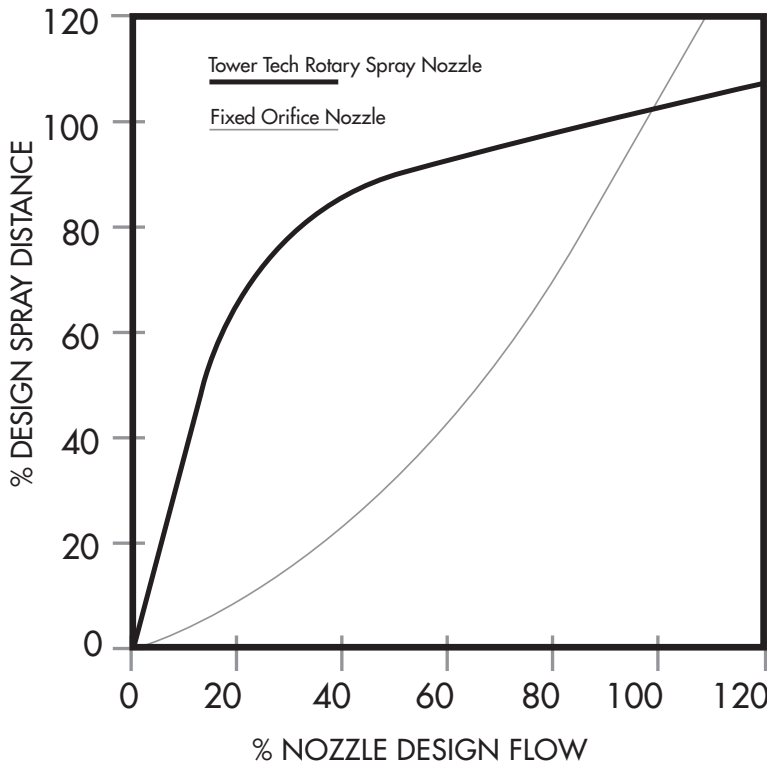

The chart demonstrates the constancy in spray pattern coverage at varying flow rates using the Rotary Spray Nozzle™. The nozzle orifice is shaped to provide an even square spray pattern, thereby uniformly wetting the entire tower's fill. This improves tower performance and reduces the likelihood of scaling due to the occurrence of dry regions within the fill. Variable-flow capability stems from the unique spring-actuated orifice which allows the nozzle to automatically adjust its pattern to changes in the flow rate, significantly reducing the down turn in performance observed with conventional nozzle designs. While conventional towers require a reduction in cell usage when system flow decreases, TTXL technology permits this reduced flow to be evenly distributed over all available fill area. This results in maximizing cooling capacity and energy efficiency under partial load duties.

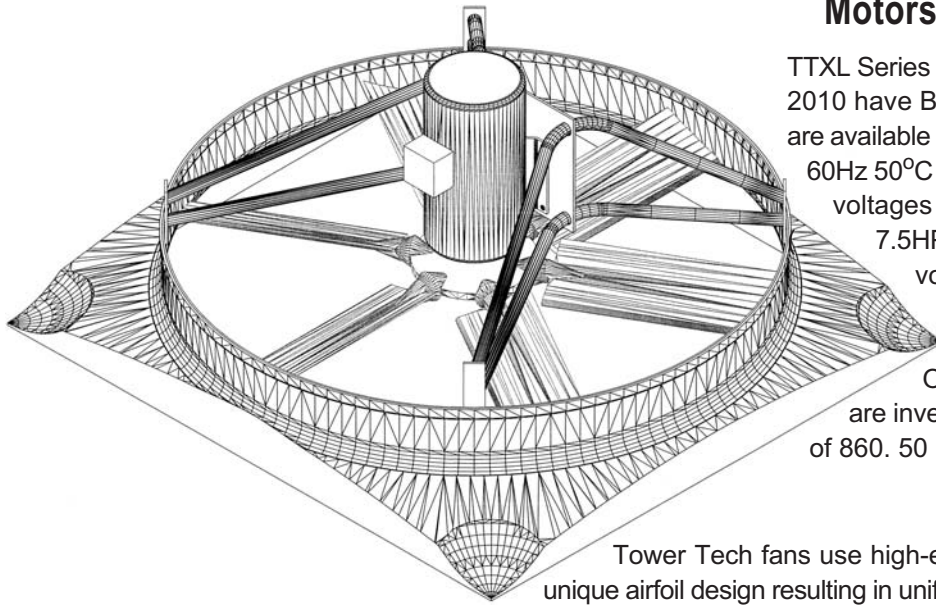

Motors / Fans / Shrouds

TTXL Series Modular Cooling Towers shipped after October 2010 have Baldor direct-drive motors. 60Hz 40°C motors are available in various voltages at 3.0HP, 5.0HP and 7.5HP. 60Hz 50°C and 50Hz 40°C motors are available in various voltages at 2.2kW (3.0HP), 3.7kW (5.0HP) and 5.6kW (7.5HP). 50Hz 50°C motors are available in various voltages at 2.9kW (4.0HP) and 4.5kW (6.0HP). All standard Baldor motors have a 210T Series size frame, are TEAO (Totally Enclosed Air Over), L₁₀ (100,000 hour) sealed bearings, and are inverter ready. 60 Hz motors have a nominal RPM of 860. 50 Hz motors have a nominal RPM of 715.

Tower Tech fans use high-efficiency, molded thermoplastic blades with a unique airfoil design resulting in uniform airflow, minimal turbulence, and maximized system efficiency. Adjustable-pitch blades along with lightweight, high-strength cast aluminum-silicon alloy hubs simplify field adjustments. Blade tip tolerances are quality control validated in order to ensure maximum system efficiencies. Tower Tech's stainless steel tubular motor mount provides minimum air turbulence, reduced fan noise, and long life for support of mechanical equipment.

The TTXL Series precision molded fan shroud is manufactured using hand-laid fiberglass techniques. It is engineered to provide a smooth air entry (optimized r/d) and approach velocity. The heavy-duty fiberglass shroud is lightweight and will resist corrosion indefinitely.

Fill & Drift Eliminators

TTXL Series cooling towers are equipped with rigid cross-corrugated, high-efficiency PVC film fill media (10 mil thickness). This fill media is resistant to biological degradation and to most chemicals (inorganic alkalis or acids, as well as organics) common to cooling tower systems. Its high surface area to volume ratio provides optimum heat exchange efficiency. The TTXL tower shell may be equipped with configurations to meet any water quality demand – alternative thermal capacity ratings are available from your Tower Tech design engineer. In addition to PVC, TTXL Series towers may be optionally equipped with HPVC fill suitable for use in “hot water” applications within a working range of 130° to 155°F (54.4° to 60°C). Alternative 15 mil thickness material is also available as a specified option.

TTXL Series cooling towers are equipped with low-pressure sinusoidal-wave shaped PVC drift eliminators (15 mil finished thickness). These high-efficiency cells (drift loss guaranteed not to exceed 0.0004%) force the exiting airstream to make three distinct directional changes causing exiting moisture droplets to impinge and coalesce on its high surface areas. The PVC material used in the construction is virtually impervious to rot, decay, or biological attack. An ultraviolet inhibitor manufactured into the product extends the life expectancy.

Materials of Construction

The Tower Tech TTXL Series cooling tower structure is factory-assembled and constructed entirely of fiberglass and stainless steel hardware, which together provide a rigid shell and framework for the tower that will resist deterioration and corrosion indefinitely. There are no galvanized or wood components which may leak potentially hazardous chemicals into the environment. Walls are joined together by tongue and groove joints and are sealed by a polyurethane sealant to prevent leaks. Stainless steel fasteners employing coated threads (in wetted areas) are used to bolt the walls together and ensure leak-free operation under pressurized operating conditions.

Component	Material	Component	Material
Corner Enclosures	FRP (pultruded)	Sub-structure Legs	FRP (pultruded)
Shell/Casing	FRP (pultruded)	Windwall Partitions	ABS (extruded)
Fill Media	10 mil PVC	Modular Base Support	Nylon (injection molded)
Drift Eliminators	15 mil PVC	Fan Shroud	Hand-laid Fiberglass
Rotary Spray Nozzle™ (injection molded)	HDPE & Stainless Steel	Sump Box	PP (rotational mold)
Lateral Distribution	ABS	Inspection Ports	Nylon (injection molded)
Water Collection System™	ABS (injection molded & extruded)	Hardware	304 Stainless Steel
Header Inlet	PVC (injection molded)	Fan Support	304 Stainless Steel

Where FRP = Fiber-glass Reinforced, plastic Pultrusion; PVC = Poly Vinyl Chloride; HDPE = High Density Poly-Ethylene; ABS=Acrylonitrile, 1,3 Butadiene, and Styrene Copolymer, Flame Retardant; PP = Poly-Propylene.

Weights and Dimensions

TTXL Model	Weights in Lbs. (kg)		Dimensions per Illustration Below ^a (cm)							
	Shipping	Operating	A	B	C	D	E	F	G	H
i219xx	5,245 (2,379)	9,609 (4,360)	7'-00" (213.4)	3'-06" (106.7)	10'-01" (307.3)	1'-04" (40.6)	4'-00" (121.9)	6'-00" (182.9)	17'-00" (518.2)	13'-06" (411.5)
i319xx	7,040 (3,194)	13,128 (5,956)	7'-00" (213.4)	3'-06" (106.7)	10'-01" (307.3)	1'-04" (40.6)	4'-00" (121.9)	6'-00" (182.9)	17'-00" (518.2)	19'-03" (586.7)
i419xx	8,835 (4,008)	16,641 (7,550)	7'-00" (213.4)	3'-06" (106.7)	10'-01" (307.3)	1'-04" (40.6)	4'-00" (121.9)	6'-00" (182.9)	17'-00" (518.2)	25'-00" (762.0)
0419xx	7,912 (3,590)	13,758 (6,242)	12'-00" (365.8)	6'-00" (182.9)	9'-11" (302.3)	1'-04" (40.6)	6'-00" (182.9)	6'-00" (182.9)	17'-00" (518.2)	13'-06" (411.5)
i519xx	10,630 (4,823)	20,163 (9,148)	7'-00" (213.4)	3'-06" (106.7)	10'-01" (307.3)	1'-04" (40.6)	4'-00" (121.9)	6'-00" (182.9)	17'-00" (518.2)	30'-09" (937.3)
0619xx	11,662 (5,291)	19,727 (8,950)	12'-00" (365.8)	6'-00" (182.9)	9'-11" (302.3)	1'-04" (40.6)	6'-00" (182.9)	6'-00" (182.9)	17'-00" (518.2)	19'-03" (586.7)
0819xx	15,412 (6,993)	25,695 (11,658)	12'-00" (365.8)	6'-00" (182.9)	9'-11" (302.3)	1'-04" (40.6)	6'-00" (182.9)	6'-00" (182.9)	17'-00" (518.2)	25'-00" (762.0)
1019xx	19,162 (8,694)	31,655 (14,362)	12'-00" (365.8)	6'-00" (182.9)	9'-11" (302.3)	1'-04" (40.6)	6'-00" (182.9)	6'-00" (182.9)	17'-00" (518.2)	30'-09" (937.3)
1219xx	22,912 (10,395)	37,623 (17,070)	12'-00" (365.8)	6'-00" (182.9)	9'-11" (302.3)	1'-04" (40.6)	^b	6'-00" (182.9)	17'-00" (518.2)	36'-06" (1,112.5)

^a Dimensions are approximate and should not be used for construction purposes. Dimension F may be 1'-00" (30.5 cm), 4'-00" (121.9 cm), 6'-00" (182.9 cm), 8'-00" (243.8 cm), 10'-00" (304.8 cm), or 12'-00" (365.8 cm) depending on project requirements. 12'-00" (365.8 cm) may be specified with prior approval of Tower Tech engineering manager only. Dimension F on drawing below is 6'-00" (182.9 cm).

^b TTXL-1219xx requires two sumps. See TTXL-1219xx drawings on Tower Tech website.

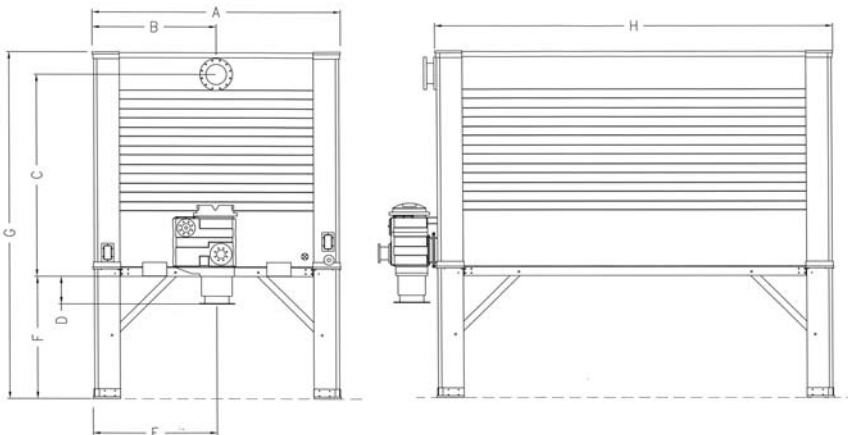

Model	Fan Motors 3 Phase, 60 Hz, 40° C., 200V, 230V, 460V or 575V										Connections ^c						
	TTXL	No. Fans	kW / Fan	kW / Module	HP / Fan	HP / Module	Volts	FLA / Fan	FLA / Module	SFA (MMC) / Fan ^a	SFA (MMC) / Module ^a	Eff'y ^b	RPM	S.F.	Inlet Dia.	Outlet Dia.	Makeup Dia.
i21930	2	2.2	4.4	3.0	6.0	200	12.1	24.2	13.3	26.6	84.0%	865	1.15	6" (150mm)	8" (200mm)	1" FNPT (25mm)	4" (100mm)
						230	11.2	22.4	12.2	24.3							
						460	5.6	11.2	6.2	12.3							
						575	4.5	9.0	5.2	10.4							
i21950		3.7	7.4	5.0	10.0	200	20.0	40.0	22.0	44.0	85.5%	855					
						230	16.6	33.2	18.3	36.5							
						460	8.3	16.6	9.2	18.4							
						575	6.7	13.4	7.7	15.4							
i21975		5.6	11.2	7.5	15.0	200	30.0	60.0	33.0	66.0	81.5%	850					
						230	24.6	49.2	27.7	55.3							
						460	12.3	24.6	13.8	27.5							
						575	10.3	20.6	11.4	22.8							
i31930	3	2.2	6.6	3.0	9.0	200	12.1	36.3	13.3	39.9	84.0%	865	1.15	8" (200mm)	8" (200mm)	1" FNPT (25mm)	4" (100mm)
						230	11.2	33.6	12.2	36.5							
						460	5.6	16.8	6.2	18.3							
						575	4.5	13.5	5.2	15.5							
i31950		3.7	11.1	5.0	15.0	200	20.0	60.0	22.0	66.0	85.5%	855					
						230	16.6	49.8	18.3	54.8							
						460	8.3	24.9	9.2	27.6							
						575	6.7	20.1	7.7	23.1							
i31975		5.6	16.8	7.5	22.5	200	30.0	90.0	33.0	99.0	81.5%	850					
						230	24.6	73.8	27.7	82.9							
						460	12.3	36.9	13.8	41.3							
						575	10.3	30.9	11.4	34.2							
i41930	4	2.2	8.8	3.0	12.0	200	12.1	48.4	13.3	53.2	84.0%	865	1.15	8" (200mm)	10" (250mm)	2" FNPT (50mm)	6" (150mm)
						230	11.2	44.8	12.2	48.6							
						460	5.6	22.4	6.2	24.6							
						575	4.5	18.0	5.2	20.7							
i41950		3.7	14.8	5.0	20.0	200	20.0	80.0	22.0	88.0	85.5%	855					
						230	16.6	66.4	18.3	73.0							
						460	8.3	33.2	9.2	36.7							
						575	6.7	26.8	7.7	30.8							
i41975		5.6	22.4	7.5	30.0	200	30.0	120.0	33.0	132.0	81.5%	850					
						230	24.6	98.4	27.7	110.5							
						460	12.3	49.2	13.8	55.1							
						575	10.3	41.2	11.4	45.6							
041930	4	2.2	8.8	3.0	12.0	200	12.1	48.4	13.3	53.2	84.0%	865	1.15	10" (250mm)	10" (250mm)	2" FNPT (50mm)	6" (150mm)
						230	11.2	44.8	12.2	48.6							
						460	5.6	22.4	6.2	24.6							
						575	4.5	18.0	5.2	20.7							
041950		3.7	14.8	5.0	20.0	200	20.0	80.0	22.0	88.0	85.5%	855					
						230	16.6	66.4	18.3	73.0							
						460	8.3	33.2	9.2	36.7							
						575	6.7	26.8	7.7	30.8							
041975		5.6	22.4	7.5	30.0	200	30.0	120.0	33.0	132.0	81.5%	850					
						230	24.6	98.4	27.7	110.5							
						460	12.3	49.2	13.8	55.1							
						575	10.3	41.2	11.4	45.6							
i51930	5	2.2	11	3.0	15.0	200	12.1	60.5	13.3	69.5	84.0%	865	1.15	8" (200mm)	10" (250mm)	2" FNPT (50mm)	6" (150mm)
						230	11.2	56.0	12.2	60.8							
						460	5.6	28.0	6.2	31.9							
						575	4.5	22.5	5.2	25.0							
i51950		3.7	18.5	5.0	25.0	200	20.0	92.5	22.0	106.4	85.5%	855					
						230	16.6	83.0	18.3	91.3							
						460	8.3	41.5	9.2	45.4							
						575	6.7	33.5	7.7	38.5							
i51975		5.6	28	7.5	37.5	200	30.0	132.5	33.0	152.4	81.5%	850					
						230	24.6	123.0	27.7	138.1							
						460	12.3	61.5	13.8	68.8							
						575	10.3	51.5	11.4	57.0							

Engineering Data 60 Hz, 40° C. Continued on Page 6

Model		Fan Motors 3 Phase, 60 Hz, 40° C., 200V, 230V, 460V or 575V											Connections ^c				
TTXL	No. Fans	kW / Fan	kW / Module	HP / Fan	HP / Module	Volts	FLA / Fan	FLA / Module	SFA (MMC) / Fan ^a	SFA (MMC) / Module ^a	Eff ^y ^b	RPM	S.F.	Inlet Dia.	Outlet Dia.	Makeup Dia.	Overflow Dia.
061930	6	2.2	13.2	3.0	18.0	200	12.1	72.6	13.3	79.9	84.0%	865	1.15	10" (250mm)	12" (300mm)	2" FNPT (50mm)	6" (150mm)
						230	11.2	67.2	12.2	73.0							
						460	5.6	33.6	6.2	37.0							
						575	4.5	27.0	5.2	31.0							
061950		3.7	22.2	5.0	30.0	200	20.0	120.0	22.0	132.0	85.5%	855					
						230	16.6	99.6	18.3	109.5							
						460	8.3	49.8	9.2	55.1							
						575	6.7	40.2	7.7	46.2							
061975		5.6	33.6	7.5	45.0	200	30.0	180.0	33.0	198.0	81.5%	850					
						230	24.6	147.6	27.7	165.8							
						460	12.3	73.8	13.8	82.1							
						575	10.3	61.8	11.4	68.4							
081930	8	2.2	17.6	3.0	24.0	200	12.1	96.8	13.3	106.5	84.0%	865	1.15	12" (300mm)	14" (350mm)	2" FNPT (50mm)	6" (150mm)
						230	11.2	89.6	12.2	97.3							
						460	5.6	44.8	6.2	49.3							
						575	4.5	36.0	5.2	41.4							
081950		3.7	29.6	5.0	40.0	200	20.0	160.0	22.0	176.0	85.5%	855					
						230	16.6	132.8	18.3	146.0							
						460	8.3	66.4	9.2	73.5							
						575	6.7	53.6	7.7	61.6							
081975		5.6	44.8	7.5	60.0	200	30.0	240.0	33.0	264.0	81.5%	850					
						230	24.6	196.8	27.7	221.0							
						460	12.3	98.4	13.8	110.1							
						575	10.3	82.4	11.4	91.2							
101930	10	2.2	22	3.0	30.0	200	12.1	121.0	13.3	133.1	84.0%	865	1.15	12" (300mm)	14" (350mm)	2" FNPT (50mm)	6" (150mm)
						230	11.2	112.0	12.2	121.6							
						460	5.6	56.0	6.2	61.4							
						575	4.5	45.0	5.2	51.8							
101950		3.7	37	5.0	50.0	200	20.0	200.0	22.0	220.0	85.5%	855					
						230	16.6	166.0	18.3	182.5							
						460	8.3	83.0	9.2	91.8							
						575	6.7	67.0	7.7	77.1							
101975		5.6	56	7.5	75.0	200	30.0	265.0	33.0	304.8	81.5%	850					
						230	24.6	246.0	27.7	276.3							
						460	12.3	123.0	13.8	137.6							
						575	10.3	103.0	11.4	114.0							
121930	12	2.2	26.4	3.0	36.0	200	12.1	145.2	13.3	167.0	84.0%	865	1.15	12" (300mm)	12" x 2" ^d (300mm x 2)	2" FNPT (50mm)	6" (150mm)
						230	11.2	134.4	12.2	145.9							
						460	5.6	67.2	6.2	74.1							
						575	4.5	54.0	5.2	62.1							
121950		3.7	44.4	5.0	60.0	200	20.0	220.0	22.0	255.3	85.5%	855					
						230	16.6	199.2	18.3	219.0							
						460	8.3	99.6	9.2	108.9							
						575	6.7	80.4	7.7	92.5							
121975		5.6	67.2	7.5	90.0	200	30.0	318.0	33.0	365.7	81.5%	850					
						230	24.6	295.2	27.7	331.5							
						460	12.3	147.6	13.8	165.2							
						575	10.3	123.6	11.4	136.8							

^a Baldor motor data. SFA (MMC) refers to Service Factor Amps (Maximum Motor Current). VFD should be sized for SFA (MMC).
^b Rating is NEMA nominal efficiency. Standard motors, TEAO severe duty, direct drive, with L₁₀ 100,000 hour sealed bearings, inverter ready, with quantum shield wiring, class "H" insulation (minimum).
^c Metric dimensions approximate.
^d TTXL-12 requires two sump containers. See TTXL-12 drawings for details.

Model		Fan Motors 3 Phase, 60 Hz, 50° C., 380V or 460V										Connections ^c																														
TTXL	No. Fans	kW / Fan	kW / Module	HP / Fan	HP / Module	Volts	FLA / Fan	FLA / Module	SFA (MMC) / Fan ^a	SFA (MMC) / Module ^a	Eff'y ^b	RPM	S.F.	Inlet Dia.	Outlet Dia.	Makeup Dia.	Overflow Dia.																									
i21930	2	2.2	4.4	3.0	6.0	380	6.7	13.4	7.3	14.6	84.0%	865	1.15	6" (150mm)	8" (200mm)	1" FNPT (25mm)	4" (100mm)																									
						460	5.6	11.2	6.2	12.3																																
i21950	2	3.7	7.4	5.0	10.0	380	10.1	20.2	11.3	22.6	85.5%	855						1.15	6" (150mm)	8" (200mm)	1" FNPT (25mm)	4" (100mm)																				
						460	8.3	16.6	9.2	18.4																																
i21975	2	5.6	11.2	7.5	15.0	380	15.0	30.0	16.7	33.4	81.5%	850											1.15	6" (150mm)	8" (200mm)	1" FNPT (25mm)	4" (100mm)															
						460	12.3	24.6	13.8	27.5																																
i31930	3	2.2	6.6	3.0	9.0	380	6.7	20.1	7.3	21.9	84.0%	865																1.15	8" (200mm)	8" (200mm)	1" FNPT (25mm)	4" (100mm)										
						460	5.6	16.8	6.2	18.3																																
i31950	3	3.7	11.1	5.0	15.0	380	10.1	30.3	11.3	33.9	85.5%	855																					1.15	8" (200mm)	8" (200mm)	1" FNPT (25mm)	4" (100mm)					
						460	8.3	24.9	9.2	27.6																																
i31975	3	5.6	16.8	7.5	22.5	380	15.0	45.0	16.7	50.1	81.5%	850																										1.15	8" (200mm)	8" (200mm)	1" FNPT (25mm)	4" (100mm)
						460	12.3	36.9	13.8	41.4																																
i41930	4	2.2	8.8	3.0	12.0	380	6.7	26.8	7.3	29.2	84.0%	865	1.15	8" (200mm)	10" (250mm)	2" FNPT (50mm)	6" (150mm)																									
						460	5.6	22.4	6.2	24.8																																
i41950	4	3.7	14.8	5.0	20.0	380	10.1	40.4	11.3	45.2	85.5%	855						1.15	8" (200mm)	10" (250mm)	2" FNPT (50mm)	6" (150mm)																				
						460	8.3	33.2	9.2	36.8																																
i41975	4	5.6	22.4	7.5	30.0	380	15.0	60.0	16.7	66.8	81.5%	850											1.15	8" (200mm)	10" (250mm)	2" FNPT (50mm)	6" (150mm)															
						460	12.3	49.2	13.8	55.2																																
041930	4	2.2	8.8	3.0	12.0	380	6.7	26.8	7.3	29.2	84.0%	865																1.15	10" (250mm)	10" (250mm)	2" FNPT (50mm)	6" (150mm)										
						460	5.6	22.4	6.2	24.8																																
041950	4	3.7	14.8	5.0	20.0	380	10.1	40.4	11.3	45.2	85.5%	855																					1.15	10" (250mm)	10" (250mm)	2" FNPT (50mm)	6" (150mm)					
						460	8.3	33.2	9.2	36.8																																
041975	4	5.6	22.4	7.5	30.0	380	15.0	60.0	16.7	66.8	81.5%	850																										1.15	10" (250mm)	10" (250mm)	2" FNPT (50mm)	6" (150mm)
						460	12.3	49.2	13.8	55.2																																
i51930	5	2.2	11.0	3.0	15.0	380	6.7	33.5	7.3	36.5	84.0%	865	1.15	8" (200mm)	10" (250mm)	2" FNPT (50mm)	6" (150mm)																									
						460	5.6	28.0	6.2	32.5																																
i51950	5	3.7	18.5	5.0	25.0	380	10.1	50.5	11.3	56.5	85.5%	855						1.15	8" (200mm)	10" (250mm)	2" FNPT (50mm)	6" (150mm)																				
						460	8.3	41.5	9.2	46																																
i51975	5	5.6	28.0	7.5	37.5	380	15.0	75.0	16.7	83.5	81.5%	850											1.15	8" (200mm)	10" (250mm)	2" FNPT (50mm)	6" (150mm)															
						460	12.3	61.5	13.8	69.0																																
061930	6	2.2	13.2	3.0	18.0	380	6.7	40.2	7.3	43.8	84.0%	865																1.15	10" (250mm)	12" (300mm)	2" FNPT (50mm)	6" (150mm)										
						460	5.6	33.6	6.2	37.2																																
061950	6	3.7	22.2	5.0	30.0	380	10.1	60.6	11.3	67.8	85.5%	855																					1.15	10" (250mm)	12" (300mm)	2" FNPT (50mm)	6" (150mm)					
						460	8.3	49.8	9.2	55.2																																
061975	6	5.6	33.6	7.5	45.0	380	15.0	90.0	16.7	100.2	81.5%	850																										1.15	10" (250mm)	12" (300mm)	2" FNPT (50mm)	6" (150mm)
						460	12.3	73.8	13.8	82.8																																
081930	8	2.2	17.6	3.0	24.0	380	6.7	53.6	7.3	58.4	84.0%	865	1.15	12" (300mm)	14" (350mm)	2" FNPT (50mm)	6" (150mm)																									
						460	5.6	44.8	6.2	49.6																																
081950	8	3.7	29.6	5.0	40.0	380	10.1	80.8	11.3	90.4	85.5%	855						1.15	12" (300mm)	14" (350mm)	2" FNPT (50mm)	6" (150mm)																				
						460	8.3	66.4	9.2	73.6																																
081975	8	5.6	44.8	7.5	60.0	380	15.0	120.0	16.7	133.6	81.5%	850											1.15	12" (300mm)	14" (350mm)	2" FNPT (50mm)	6" (150mm)															
						460	12.3	98.4	13.8	110.4																																

Engineering Data 60 Hz, 50° C. Continued on Page 8

Model		Fan Motors 3 Phase, 60 Hz, 50° C., 380V or 460V											Connections ^c				
TTXL	No. Fans	kW / Fan	kW / Module	HP / Fan	HP / Module	Volts	FLA / Fan	FLA / Module	SFA (MMC) / Fan ^a	SFA (MMC) / Module ^a	Eff'y ^b	RPM	S.F.	Inlet Dia.	Outlet Dia.	Makeup Dia.	Overflow Dia.
101930	10	2.2	22.0	3.0	30.0	380	6.7	67.0	7.3	73.0	84.0%	865	1.15	12" (300mm)	14" (350mm)	2" FNPT (50mm)	6" (150mm)
460						5.6	56.0	6.2	62.0								
101950		3.7	37.0	5.0	50.0	380	10.1	101.0	11.3	113.0	85.5%	855					
460						8.3	83.0	9.2	92.0								
101975		5.6	56.0	7.5	75.0	380	15.0	150.0	16.7	167.0	81.5%	850					
460						12.3	123.0	13.8	138.0								
121930	12	2.2	26.4	3.0	36.0	380	6.7	80.4	7.3	87.6	84.0%	865	1.15	12" (300mm)	12" x 2 ^d (300mm x 2)	2" FNPT (50mm)	6" (150mm)
460						5.6	67.2	6.2	74.4								
121950		3.7	44.4	5.0	60.0	380	10.1	121.2	11.3	135.6	85.5%	855					
460						8.3	99.6	9.2	110.4								
121975		5.6	67.2	7.5	90.0	380	15.0	180.0	16.7	200.4	81.5%	850					
460						12.3	147.6	13.8	165.6								

^a Baldor motor data. SFA (MMC) refers to Service Factor Amps (Maximum Motor Current). VFD should be sized for SFA (MMC).

^b Rating is NEMA nominal efficiency. Standard motors, TEAO severe duty, direct drive, with L₁₀ 100,000 hour sealed bearings, inverter ready, with quantum shield wiring, class "H" insulation (minimum).

^c Metric dimensions approximate.

^d TTXL-12 requires two sump containers. See TTXL-12 drawings for details.



Model		Fan Motors 3 Phase, 50 Hz, 40° C., 190V or 380V										Connections ^c					
TTXL	No. Fans	kW / Fan	kW / Module	HP / Fan	HP / Module	Volts	FLA / Fan	FLA / Module	SFA (MMC) / Fan ^a	SFA (MMC) / Module ^a	Eff ^y ^b	RPM	S.F.	Inlet Dia.	Outlet Dia.	Makeup Dia.	Overflow Dia.
i21922	2	2.2	4.4	3.0	6.0	190	10.0	20.0	10.9	21.8	84.0%	720	1.15	6" (150mm)	8" (200mm)	1" FNPT (25mm)	4" (100mm)
						380	5.0	10.0	5.5	11.0							
i21937		3.7	7.4	5.0	10.0	190	18.8	37.6	20.3	40.6	85.5%	700	1.10				
						380	9.4	18.8	10.1	20.2							
i21956		5.6	11.2	7.5	15.0	190	28.6	57.2	31.8	63.6	81.5%	700	1.15				
						380	14.3	28.6	15.9	31.8							
i31922	3	2.2	6.6	3.0	9.0	190	10.0	30.0	10.9	32.7	84.0%	720	1.15	8" (200mm)	8" (200mm)	1" FNPT (25mm)	4" (100mm)
						380	5.0	15.0	5.5	16.5							
i31937		3.7	11.1	5.0	15.0	190	18.8	56.4	20.3	60.9	85.5%	700	1.10				
						380	9.4	28.2	10.1	30.3							
i31956		5.6	16.8	7.5	22.5	190	28.6	85.8	31.8	95.4	81.5%	700	1.15				
						380	14.3	42.9	15.9	47.7							
i41922	4	2.2	8.8	3.0	12.0	190	10.0	40.0	10.9	43.6	84.0%	720	1.15	8" (200mm)	10" (250mm)	2" FNPT (50mm)	6" (150mm)
						380	5.0	20.0	5.5	22.0							
i41937		3.7	14.8	5.0	20.0	190	18.8	75.2	20.3	81.2	85.5%	700	1.10				
						380	9.4	37.6	10.1	40.4							
i41956		5.6	22.4	7.5	30.0	190	28.6	114.4	31.8	127.2	81.5%	700	1.15				
						380	14.3	57.2	15.9	63.6							
041922	4	2.2	8.8	3.0	12.0	190	10.0	40.0	10.9	43.6	84.0%	720	1.15	10" (250mm)	10" (250mm)	2" FNPT (50mm)	6" (150mm)
						380	5.0	20.0	5.5	22.0							
041937		3.7	14.8	5.0	20.0	190	18.8	75.2	20.3	81.2	85.5%	700	1.10				
						380	9.4	37.6	10.1	40.4							
041956		5.6	22.4	7.5	30.0	190	28.6	114.4	31.8	127.2	81.5%	700	1.15				
						380	14.3	57.2	15.9	63.6							
i51922	5	2.2	11.0	3.0	15.0	190	10.0	50.0	10.9	54.5	84.0%	720	1.15	8" (200mm)	10" (250mm)	2" FNPT (50mm)	6" (150mm)
						380	5.0	25.0	5.5	27.5							
i51937		3.7	18.5	5.0	25.0	190	18.8	94.0	20.3	101.5	85.5%	700	1.10				
						380	9.4	47.0	10.1	50.5							
i51956		5.6	28.0	7.5	37.5	190	28.6	143.0	31.8	159.0	81.5%	700	1.15				
						380	14.3	71.5	15.9	79.5							
061922	6	2.2	13.2	3.0	18.0	190	10.0	60.0	10.9	65.4	84.0%	720	1.15	10" (250mm)	12" (300mm)	2" FNPT (50mm)	6" (150mm)
						380	5.0	30.0	5.5	33.0							
061937		3.7	22.2	5.0	30.0	190	18.8	112.8	20.3	121.8	85.5%	700	1.10				
						380	9.4	56.4	10.1	60.6							
061956		5.6	33.6	7.5	45.0	190	28.6	171.6	31.8	190.8	81.5%	700	1.15				
						380	14.3	85.8	15.9	95.4							
081922	8	2.2	17.6	3.0	24.0	190	10.0	80.0	10.9	87.2	84.0%	720	1.15	12" (300mm)	14" (350mm)	2" FNPT (50mm)	6" (150mm)
						380	5.0	40.0	5.5	44.0							
081937		3.7	29.6	5.0	40.0	190	18.8	150.4	20.3	162.4	85.5%	700	1.10				
						380	9.4	75.2	10.1	80.8							
081956		5.6	44.8	7.5	60.0	190	28.6	228.8	31.8	254.4	81.5%	700	1.15				
						380	14.3	114.4	15.9	127.2							

Engineering Data 50 Hz, 40° C. Continued on Page 10

Model		Fan Motors 3 Phase, 50 Hz, 40° C., 190V or 380V										Connections ^c					
TTXL	No. Fans	kW / Fan	kW / Module	HP / Fan	HP / Module	Volts	FLA / Fan	FLA / Module	SFA (MMC) / Fan ^a	SFA (MMC) / Module ^a	Eff'y ^b	RPM	S.F.	Inlet Dia.	Outlet Dia.	Makeup Dia.	Overflow Dia.
101922	10	2.2	22.0	3.0	30.0	190	10.0	100.0	10.9	109.0	84.0%	720	1.15	12" (300mm)	14" (350mm)	2" FNPT (50mm)	6" (150mm)
380						5.0	50.0	5.5	55.0								
101937		3.7	37.0	5.0	50.0	190	18.8	188.0	20.3	203.0	85.5%	700	1.10				
380						9.4	94.0	10.1	101.0								
101956		5.6	56.0	7.5	75.0	190	28.6	286.0	31.8	318.0	81.5%	700	1.15				
380						14.3	143.0	15.9	159.0								
121922	12	2.2	26.4	3.0	36.0	190	10.0	120.0	10.9	130.8	84.0%	720	1.15	12" (300mm)	12" x 2 ^d (300mm x 2)	2" FNPT (50mm)	6" (150mm)
380						5.0	60.0	5.5	66.0								
121937		3.7	44.4	5.0	48.0	190	18.8	225.6	20.3	243.6	85.5%	700	1.10				
380						9.4	112.8	10.1	121.2								
121956		5.6	67.2	7.5	90.0	190	28.6	343.2	31.8	381.6	81.5%	700	1.15				
380						14.3	171.6	15.9	190.8								

^a Baldor motor data. SFA (MMC) refers to Service Factor Amps (Maximum Motor Current). VFD should be sized for SFA (MMC).
^b Rating is NEMA nominal efficiency. Standard motors, TEAO severe duty, direct drive, with L₁₀ 100,000 hour sealed bearings, inverter ready, with quantum shield wiring, class "H" insulation (minimum).
^c Metric dimensions approximate.
^d TTXL-12 requires two sump containers. See TTXL-12 drawings for details.



Model	Fan Motors 3 Phase, 50 Hz, 50° C., 190V or 380V											Connections ^c					
	TTXL	No. Fans	kW / Fan	kW / Module	HP / Fan	HP / Module	Volts	FLA / Fan	FLA / Module	SFA (MMC) / Fan ^a	SFA (MMC) / Module ^a	Eff'y ^b	RPM	S.F.	Inlet Dia.	Outlet Dia.	Makeup Dia.
i21929	2	2.9	5.8	4.0	8.0	190	16.2	32.4	17.8	35.6	85.5%	710	1.15	6" (150mm)	8" (200mm)	1" FNPT (25mm)	4" (100mm)
						380	8.1	16.2	8.9	17.8							
i21945	2	4.5	9.0	6.0	12.0	190	24.0	48.0	26.9	53.8	81.5%	715	1.15	6" (150mm)	8" (200mm)	1" FNPT (25mm)	4" (100mm)
						380	12.0	24.0	13.4	26.8							
i31929	3	2.9	8.7	4.0	12.0	190	16.2	48.6	17.8	53.4	85.5%	710	1.15	8" (200mm)	8" (200mm)	1" FNPT (25mm)	4" (100mm)
						380	8.1	24.3	8.9	26.7							
i31945	3	4.5	13.5	6.0	18.0	190	24.0	72.0	26.9	80.7	81.5%	715	1.15	8" (200mm)	8" (200mm)	1" FNPT (25mm)	4" (100mm)
						380	12.0	36.0	13.4	40.2							
i41929	4	2.9	11.6	4.0	16.0	190	16.2	64.8	17.8	71.2	85.5%	710	1.15	8" (200mm)	10" (250mm)	2" FNPT (50mm)	6" (150mm)
						380	8.1	32.4	8.9	35.6							
i41945	4	4.5	18.0	6.0	24.0	190	24.0	96.0	26.9	107.6	81.5%	715	1.15	8" (200mm)	10" (250mm)	2" FNPT (50mm)	6" (150mm)
						380	12.0	48.0	13.4	53.6							
041929	4	2.9	11.6	4.0	16.0	190	16.2	64.8	17.8	71.2	85.5%	710	1.15	10" (250mm)	10" (250mm)	2" FNPT (50mm)	6" (150mm)
						380	8.1	32.4	8.9	35.6							
041945	4	4.5	18.0	6.0	24.0	190	24.0	96.0	26.9	107.6	81.5%	715	1.15	10" (250mm)	10" (250mm)	2" FNPT (50mm)	6" (150mm)
						380	12.0	48.0	13.4	53.6							
i51929	5	2.9	14.5	4.0	20.0	190	16.2	81.0	17.8	89.0	85.5%	710	1.15	8" (200mm)	10" (250mm)	2" FNPT (50mm)	6" (150mm)
						380	8.1	40.5	8.9	44.5							
i51945	5	4.5	22.5	6.0	30.0	190	24.0	120.0	26.9	134.5	81.5%	715	1.15	8" (200mm)	10" (250mm)	2" FNPT (50mm)	6" (150mm)
						380	12.0	60.0	13.4	67.0							
061929	6	2.9	17.4	4.0	24.0	190	16.2	97.2	17.8	106.8	85.5%	710	1.15	10" (250mm)	12" (300mm)	2" FNPT (50mm)	6" (150mm)
						380	8.1	48.6	8.9	53.4							
061945	6	4.5	27.0	6.0	36.0	190	24.0	144.0	26.9	161.4	81.5%	715	1.15	10" (250mm)	12" (300mm)	2" FNPT (50mm)	6" (150mm)
						380	12.0	72.0	13.4	80.4							
081929	8	2.9	23.2	4.0	32.0	190	16.2	129.6	17.8	142.4	85.5%	710	1.15	12" (300mm)	14" (350mm)	2" FNPT (50mm)	6" (150mm)
						380	8.1	64.8	8.9	71.2							
081945	8	4.5	36.0	6.0	48.0	190	24.0	192.0	26.9	215.2	81.5%	715	1.15	12" (300mm)	14" (350mm)	2" FNPT (50mm)	6" (150mm)
						380	12.0	96.0	13.4	107.2							
101929	10	2.9	29.0	4.0	40.0	190	16.2	162.0	17.8	178.0	85.5%	710	1.15	12" (300mm)	14" (350mm)	2" FNPT (50mm)	6" (150mm)
						380	8.1	81.0	8.9	89.0							
101945	10	4.5	45.0	6.0	60.0	190	24.0	240.0	26.9	269.0	81.5%	715	1.15	12" (300mm)	14" (350mm)	2" FNPT (50mm)	6" (150mm)
						380	12.0	120.0	13.4	134.0							
121929	12	2.9	34.8	4.0	48.0	190	16.2	194.4	17.8	213.6	85.5%	710	1.15	12" (300mm)	12" x 2 ^d (300mm x 2)	2" FNPT (50mm)	6" (150mm)
						380	8.1	97.2	8.9	106.8							
121945	12	4.5	54.0	6.0	72.0	190	24.0	288.0	26.9	322.8	81.5%	715	1.15	12" (300mm)	12" x 2 ^d (300mm x 2)	2" FNPT (50mm)	6" (150mm)
						380	12.0	144.0	13.4	160.8							

^a Baldor motor data. SFA (MMC) refers to Service Factor Amps (Maximum Motor Current). VFD should be sized for SFA (MMC).

^b Rating is NEMA nominal efficiency. Standard motors, TEAO severe duty, direct drive, with L₁₀ 100,000 hour sealed bearings, inverter ready, with quantum shield wiring, class "H" insulation (minimum).

^c Metric dimensions approximate.

^d TTXL-12 requires two sump containers. See TTXL-12 drawings for details.

Variable Flow Offers Lowest \$ kW/Ton

Conventional water distribution in cooling towers sacrifices valuable energy saving opportunities. This fact is even more pronounced in today's water filming style heat transfer medias.

The efficiency of evaporative heat transfer is affected by the air-to-water contact area and the mass flow liquid-to-gas ratio. In general, for a given heat load and water mass flow rate, the more surface area involved, the less required air velocity over the water surface, and consequently the less air-moving fan horsepower. If you want lower kW/ton, buy more air-to-water contact surface area.

Film media, such as the popular PVC cross-fluted corrugated film block, provides a breakthrough in cooling tower design. It greatly increases the contact surface area without increasing the size of the tower box. Adversely, it suffers quickly from scaling and biomass fouling in very compact air channels that negatively impact the flow of air.

Precise water treatment is required to prevent bio growth fouling and the fill must remain "wetted" to avoid evaporative scaling. Conventional water distribution uses fixed orifice spray nozzles that produce a round pattern above a rectangular fill pack. The nozzles are placed in a rectangular overlapping pattern to assure full wetting of the fill at the design water flow rate.

Water flow rates below the design point will not produce a full spray pattern and void areas will start to appear. Any fill's best efficiency is achieved when the liquid-to-gas ratio is evenly balanced throughout the fill media. Short patterns and overlapping patterns cannot accomplish it.

When a cooling tower system is faced with a variable water flow rate (i.e. multiple pump cycling or variable speed

pumping) these pattern problems force the operator to isolate whole cooling tower cells to maintain proper water distribution under reduced load in the remaining on-line cells. If this is not done, the tower efficiency will suffer and the fill media will quickly foul. Isolating cells takes away air-to-water contact surface.

A water distribution system that can respond to variable flow rates and keep all of the fill media evenly wetted and in service is needed. This requires a nozzle that responds to flow changes to keep a constant pattern. A square pattern that avoids overlap would be best.

Putting this system on a three-cell tower with three matched pumps would yield the following opportunities. A typical tower would operate at 0.06 kW/ton for the tower alone at full load, 0.06 kW/ton at 2/3 load (two cells operating at 100%), and 0.06 kW/ton at 1/3 load (one cell operating at 100%). Under the same conditions, a constant pattern, variable spray system with variable speed drives on the fan motors would operate at 0.06 kW/ton at full load, 0.024 kW/ton at 2/3 load (all cells operating at 2/3 load), and 0.005 kW/ton at 1/3 load (all cells operating at 1/3 load).

These energy savings can only be achieved through use of a distribution system utilizing the patented Tower Tech Rotary Spray Nozzle which operates from 100 to 300 GPM. This patented system is available for evaporative water-cooling towers at one place, only: Tower Tech. Come visit us at www.TowerTechInc.com to see our complete line of factory-assembled, modular fiberglass cooling towers for flow rates from 200 gpm to 200,000 gpm and more. Our towers are CTI Certified under STD-201 for your assurance of performance. We're worth a second look for a great many reasons. Check us out.



Thermal Performance Data

Thermal capacities assume 6' (182.88 cm) air inlet.

60 Hz, 40° C.

TTXL Model	Fan Power		Cooling Capacity at Indicated Operating Conditions - GPM										
			(m ³ /hr)										
	No. of Fans	Total Power HP	HWT °F (°C)	85 (29.4)	95 (35)	87 (30.6)	90 (32.2)	95 (35)	87 (30.6)	90 (32.2)	95 (35)	92 (33.3)	100 (37.8)
			CWT °F (°C)	75 (23.9)	80 (26.7)	77 (25)	80 (26.7)	80 (26.7)	77 (25)	80 (26.7)	80 (26.7)	82 (27.8)	85 (29.4)
WBW °F (°C)	68 (20)	68 (20)	70 (21.1)	70 (21.1)	70 (21.1)	72 (22.2)	72 (22.2)	72 (22.2)	72 (22.2)	75 (23.9)	75 (23.9)		
i21930	2	6		347 (78.8)	422 (95.9)	364 (82.8)	483 (109.7)	383 (87.0)	304 (69.0)	425 (96.6)	341 (77.5)	415 (94.2)	436 (99.1)
i21950	2	10		399 (90.6)	486 (110.4)	420 (95.3)	556 (126.3)	440 (100.0)	349 (79.2)	489 (111.0)	392 (88.9)	478 (108.5)	502 (114.0)
i21975	2	15		446 (101.2)	542 (123.1)	469 (106.6)	600 (136.3)	492 (111.7)	390 (88.5)	546 (124.0)	437 (99.3)	534 (121.2)	560 (127.1)
i31930	3	9		498 (113.1)	607 (137.8)	524 (119.1)	693 (157.5)	550 (125.0)	436 (99.1)	610 (138.6)	490 (111.2)	596 (135.4)	627 (142.4)
i31950	3	15		573 (130.1)	697 (158.4)	603 (136.9)	799 (181.5)	633 (143.7)	501 (113.8)	702 (159.4)	563 (127.8)	686 (155.8)	721 (163.7)
i31975	3	22.5		640 (145.4)	779 (176.8)	673 (152.8)	893 (202.7)	706 (160.3)	559 (126.9)	784 (178.1)	627 (142.4)	765 (173.8)	804 (182.5)
i41930	4	12		649 (147.3)	789 (179.1)	119 (154.9)	903 (205.0)	716 (162.6)	567 (128.8)	794 (180.4)	637 (144.8)	776 (176.2)	816 (185.3)
i41950	4	20		746 (169.4)	907 (206.1)	786 (178.1)	1039 (236.0)	822 (186.8)	652 (148.2)	913 (207.4)	732 (166.2)	893 (202.7)	937 (212.9)
i41975	4	30		833 (189.1)	1013 (230.1)	876 (198.9)	1160 (263.6)	918 (208.4)	727 (165.1)	1020 (231.6)	816 (185.3)	996 (226.3)	1046 (237.5)
041930	4	12		640 (145.4)	779 (177.0)	674 (153.0)	892 (202.5)	707 (160.7)	561 (127.4)	784 (178.1)	629 (142.9)	766 (174.1)	806 (183.0)
041950	4	20		736 (167.3)	895 (203.4)	775 (176.0)	1025 (232.8)	812 (184.5)	644 (146.3)	902 (204.8)	722 (164.1)	880 (200.0)	925 (210.1)
041975	4	30		821 (186.6)	999 (226.9)	864 (196.3)	1146 (260.0)	907 (205.9)	718 (163.0)	1007 (228.6)	806 (183.0)	983 (223.3)	1032 (234.3)
i51930	5	15		816 (185.3)	993 (225.4)	858 (194.9)	1136 (257.9)	901 (204.6)	714 (162.2)	999 (226.9)	802 (182.1)	976 (221.6)	1025 (232.9)
i51950	5	25		937 (212.9)	1141 (259.2)	987 (224.2)	1307 (296.7)	1036 (235.0)	820 (186.2)	1149 (260.9)	921 (209.1)	1122 (254.9)	1179 (267.7)
i51975	5	37.5		1047 (237.7)	1273 (289.1)	1101 (250.0)	1459 (331.3)	1154 (262.1)	915 (207.8)	1282 (291.2)	1026 (233.1)	1251 (284.2)	1314 (298.4)
061930	6	18		919 (208.5)	1118 (253.9)	967 (219.7)	1279 (290.6)	1014 (230.3)	805 (182.8)	1125 (255.6)	902 (205.0)	1099 (249.6)	1156 (262.6)
061950	6	30		1056 (239.9)	1285 (291.9)	1111 (252.4)	1472 (334.3)	1165 (264.7)	923 (209.7)	1294 (294.0)	1036 (235.4)	1264 (287.0)	1327 (301.4)
061975	6	45		1178 (267.7)	1434 (325.6)	1240 (281.7)	1643 (373.1)	1300 (295.3)	1030 (233.9)	1444 (328.0)	1155 (262.4)	1410 (320.3)	1480 (336.2)
081930	8	24		1205 (273.7)	1467 (333.2)	1268 (288.0)	1679 (381.4)	1331 (302.3)	1055 (239.6)	1477 (335.4)	1185 (269.2)	1443 (327.7)	1517 (344.5)
081950	8	40		1386 (314.8)	1686 (382.9)	1458 (331.1)	1932 (438.7)	1529 (347.3)	1211 (275.1)	1698 (385.7)	1360 (308.8)	1658 (376.6)	1742 (395.7)
081975	8	60		1546 (351.3)	1881 (427.3)	1627 (369.6)	2156 (489.7)	1705 (387.3)	1350 (306.7)	1895 (430.5)	1516 (344.3)	1850 (420.3)	1943 (441.3)
101930	10	30		1492 (338.9)	1817 (412.6)	1571 (356.8)	2079 (472.3)	1649 (374.4)	1307 (296.7)	1830 (415.6)	1467 (333.3)	1790 (405.9)	1877 (426.4)
101950	10	50		1715 (389.7)	2088 (474.2)	1806 (410.1)	2393 (543.4)	1893 (430.1)	1500 (340.7)	2103 (477.6)	1683 (382.3)	2053 (466.3)	2157 (489.9)
101975	10	75		1915 (434.9)	2329 (529.0)	2016 (457.9)	2670 (606.4)	2111 (479.5)	1673 (380.0)	2347 (533.0)	1877 (426.2)	2290 (520.3)	2405 (546.2)
121930	12	36		1780 (404.4)	2166 (492.0)	1874 (425.6)	2479 (563.1)	1965 (446.4)	1557 (353.6)	2180 (495.2)	1749 (397.1)	2131 (484.0)	2238 (508.4)
121950	12	60		2046 (464.7)	2490 (565.5)	2152 (488.8)	2851 (647.6)	2257 (512.6)	1789 (406.3)	2507 (569.3)	2007 (455.9)	2448 (555.9)	2571 (583.9)
121975	12	90		2282 (518.4)	2777 (630.6)	2403 (545.7)	3183 (723.0)	2518 (571.8)	1994 (453.0)	2797 (635.3)	2237 (508.2)	2732 (620.5)	2867 (651.2)

Cooling Towers for Discerning Users™

Thermal Performance Data 60 Hz, 40° C. Continued on Page 14

Thermal Performance Data

Thermal capacities assume 6' (182.88 cm) air inlet.

60 Hz, 40° C.

TTXL Model	Fan Power		Cooling Capacity at Indicated Operating Conditions - GPM										
			(m ³ /hr)										
	No. of Fans	Total Power HP	HWT °F (°C)	93 (33.9)	100 (37.8)	95 (35)	100 (37.8)	93 (33.9)	105 (40.6)	97 (36.1)	95 (35)	100 (37.8)	105 (40.6)
			CWT °F (°C)	83 (28.3)	85 (29.4)	85 (29.4)	85 (29.4)	83 (28.3)	85 (29.4)	87 (30.6)	85 (29.4)	85 (29.4)	90 (32.2)
WBT °F (°C)			76 (24.4)	76 (24.4)	78 (25.6)	78 (25.6)	78 (25.6)	78 (25.6)	80 (26.7)	80 (26.7)	80 (26.7)	80 (26.7)	
i21930	2	6	426 (96.8)	413 (93.8)	449 (101.9)	364 (82.6)	356 (80.9)	320 (72.8)	473 (107.4)	375 (85.1)	309 (70.3)	498 (113.1)	
i21950	2	10	490 (111.2)	475 (107.8)	516 (117.2)	418 (94.9)	408 (92.8)	367 (83.4)	544 (123.5)	431 (97.9)	355 (80.7)	573 (130.1)	
i21975	2	15	548 (124.4)	530 (120.4)	577 (131.0)	466 (105.9)	456 (103.6)	409 (93.0)	600 (136.3)	481 (109.3)	395 (89.8)	600 (136.3)	
i31930	3	9	612 (139.0)	593 (134.8)	649 (146.5)	522 (118.7)	511 (116.1)	460 (104.4)	679 (154.3)	538 (122.3)	444 (100.8)	716 (162.6)	
i31950	3	15	704 (159.8)	682 (155.0)	741 (168.3)	600 (136.3)	587 (133.3)	527 (119.7)	781 (177.5)	619 (140.5)	509 (115.7)	822 (186.8)	
i31975	3	22.5	786 (178.5)	761 (172.8)	828 (188.1)	669 (152.0)	654 (148.6)	588 (133.5)	873 (198.3)	691 (156.9)	568 (129.1)	900 (204.4)	
i41930	4	12	796 (180.9)	773 (175.5)	838 (190.4)	680 (154.5)	664 (150.9)	598 (135.9)	884 (200.8)	701 (159.2)	578 (131.2)	932 (211.6)	
i41950	4	20	916 (208.0)	888 (201.7)	964 (219.1)	781 (177.5)	764 (173.4)	687 (156.0)	1017 (230.9)	806 (183.0)	663 (150.5)	1070 (243.0)	
i41975	4	30	1022 (232.2)	991 (225.0)	1077 (244.5)	871 (197.8)	852 (193.6)	764 (173.6)	1135 (257.7)	898 (204.0)	739 (167.9)	1194 (271.3)	
041930	4	12	786 (178.5)	763 (173.2)	828 (188.1)	672 (152.6)	656 (149.0)	591 (134.2)	873 (198.3)	693 (157.3)	571 (129.7)	919 (208.7)	
041950	4	20	904 (205.3)	876 (198.9)	952 (216.3)	771 (175.1)	753 (171.1)	678 (153.9)	1003 (227.8)	795 (180.6)	654 (148.6)	1056 (239.9)	
041975	4	30	1008 (229.0)	977 (221.8)	1063 (241.3)	859 (195.1)	840 (190.8)	754 (171.3)	1120 (254.3)	886 (201.2)	729 (165.6)	1178 (267.5)	
i51930	5	15	1002 (227.5)	971 (220.5)	1055 (239.6)	856 (194.4)	836 (190.0)	752 (170.9)	1112 (252.6)	882 (200.4)	727 (165.1)	1171 (266.0)	
i51950	5	25	1151 (261.5)	1116 (253.4)	1213 (275.5)	982 (223.1)	961 (218.2)	863 (195.9)	1278 (290.2)	1013 (230.1)	834 (189.3)	1345 (305.5)	
i51975	5	37.5	1285 (291.9)	1244 (282.5)	1353 (307.4)	1094 (248.6)	1071 (243.3)	962 (218.4)	1426 (323.9)	1129 (256.4)	929 (211.0)	1500 (340.7)	
061930	6	18	1129 (256.4)	1094 (248.6)	1189 (270.0)	964 (218.8)	941 (213.8)	847 (192.5)	1253 (284.6)	993 (225.6)	819 (185.9)	1320 (299.7)	
061950	6	30	1296 (294.4)	1256 (285.3)	1366 (310.3)	1106 (251.1)	1081 (245.6)	971 (220.5)	1439 (326.9)	1140 (259.0)	938 (213.1)	1515 (344.1)	
061975	6	45	1447 (328.6)	1401 (318.2)	1524 (346.2)	1232 (279.8)	1206 (273.8)	1081 (245.6)	1607 (364.9)	1272 (288.9)	1045 (237.3)	1690 (383.8)	
081930	8	24	1480 (336.2)	1436 (326.0)	1560 (354.3)	1264 (287.2)	1235 (280.6)	1112 (252.6)	1644 (373.4)	1303 (295.9)	1074 (243.9)	1731 (393.1)	
081950	8	40	1702 (386.5)	1649 (374.4)	1793 (407.1)	1450 (329.4)	1418 (322.2)	1275 (289.5)	1889 (429.0)	1496 (339.8)	1231 (279.6)	1988 (451.5)	
081975	8	60	1899 (431.3)	1838 (417.5)	2000 (454.2)	1617 (367.2)	1581 (359.2)	1419 (322.4)	2107 (478.7)	1668 (378.9)	1371 (311.4)	2216 (503.3)	
101930	10	30	1834 (416.5)	1779 (403.9)	1933 (439.0)	1565 (355.5)	1530 (347.5)	1377 (312.6)	2036 (462.3)	1614 (366.6)	1330 (302.1)	2143 (486.7)	
101950	10	50	2107 (478.7)	2042 (463.8)	2220 (504.1)	1796 (408.0)	1757 (399.1)	1578 (358.5)	2340 (531.3)	1853 (420.9)	1524 (346.2)	2460 (558.9)	
101975	10	75	2350 (533.8)	2277 (517.1)	2477 (562.5)	2001 (454.7)	1960 (445.1)	1757 (399.1)	2610 (592.9)	2066 (469.3)	1698 (385.7)	2744 (623.2)	
121930	12	36	2186 (496.5)	2120 (481.4)	2304 (523.2)	1866 (423.9)	1823 (414.1)	1641 (327.7)	2427 (551.3)	1923 (436.8)	1585 (360.0)	2556 (580.5)	
121950	12	60	2511 (570.4)	2434 (552.7)	2647 (601.1)	2141 (486.3)	2094 (475.7)	1881 (427.3)	2788 (633.2)	2208 (501.6)	1817 (412.6)	2934 (666.3)	
121975	12	90	2802 (636.4)	2714 (616.4)	2953 (670.8)	2386 (541.9)	2335 (530.2)	2094 (475.7)	3111 (706.6)	2463 (559.3)	2023 (459.6)	3272 (743.1)	

Cooling Towers for Discerning Users™



Thermal Performance Data

Thermal capacities assume 6' (182.88 cm) air inlet. **60 Hz, 50° C.**

TTXL Model	Fan Power		Cooling Capacity at Indicated Operating Conditions - GPM										
			(m ³ /hr)										
	No. of Fans	Total Power HP	HWT °F (°C)	85 (29.4)	95 (35)	87 (30.6)	90 (32.2)	95 (35)	87 (30.6)	90 (32.2)	95 (35)	92 (33.3)	100 (37.8)
			CWT °F (°C)	75 (23.9)	80 (26.7)	77 (25)	80 (26.7)	80 (26.7)	77 (25)	80 (26.7)	80 (26.7)	80 (26.7)	82 (27.8)
WBT °F (°C)			68 (20)	68 (20)	70 (21.1)	70 (21.1)	70 (21.1)	72 (22.2)	72 (22.2)	72 (22.2)	72 (22.2)	75 (23.9)	75 (23.9)
i21930	2	6	347 (78.8)	422 (95.9)	364 (82.8)	483 (109.7)	383 (87.0)	304 (69.0)	425 (96.6)	341 (77.5)	415 (94.2)	436 (99.1)	
i21950	2	10	399 (90.6)	486 (110.4)	420 (95.3)	556 (126.3)	440 (100.0)	349 (79.2)	489 (111.0)	392 (88.9)	478 (108.5)	502 (114.0)	
i21975	2	15	446 (101.2)	542 (123.1)	469 (106.6)	600 (136.3)	492 (111.7)	390 (88.5)	546 (124.0)	437 (99.3)	534 (121.2)	560 (127.1)	
i31930	3	9	498 (113.1)	607 (137.8)	524 (119.1)	693 (157.5)	550 (125.0)	436 (99.1)	610 (138.6)	490 (111.2)	596 (135.4)	627 (142.4)	
i31950	3	15	573 (130.1)	697 (158.4)	603 (136.9)	799 (181.5)	633 (143.7)	501 (113.8)	702 (159.4)	563 (127.8)	686 (155.8)	721 (163.7)	
i31975	3	22.5	640 (145.4)	779 (176.8)	673 (152.8)	893 (202.7)	706 (160.3)	559 (126.9)	784 (178.1)	627 (142.4)	765 (173.8)	804 (182.5)	
i41930	4	12	649 (147.3)	789 (179.1)	119 (154.9)	903 (205.0)	716 (162.6)	567 (128.8)	794 (180.4)	637 (144.8)	776 (176.2)	816 (185.3)	
i41950	4	20	746 (169.4)	907 (206.1)	786 (178.1)	1039 (236.0)	822 (186.8)	652 (148.2)	913 (207.4)	732 (166.2)	893 (202.7)	937 (212.9)	
i41975	4	30	833 (189.1)	1013 (230.1)	876 (198.9)	1160 (263.6)	918 (208.4)	727 (165.1)	1020 (231.6)	816 (185.3)	996 (226.3)	1046 (237.5)	
041930	4	12	640 (145.4)	779 (177.0)	674 (153.0)	892 (202.5)	707 (160.7)	561 (127.4)	784 (178.1)	629 (142.9)	766 (174.1)	806 (183.0)	
041950	4	20	736 (167.3)	895 (203.4)	775 (176.0)	1025 (232.8)	812 (184.5)	644 (146.3)	902 (204.8)	722 (164.1)	880 (200.0)	925 (210.1)	
041975	4	30	821 (186.6)	999 (226.9)	864 (196.3)	1146 (260.0)	907 (205.9)	718 (163.0)	1007 (228.6)	806 (183.0)	983 (223.3)	1032 (234.3)	
i51930	5	15	816 (185.3)	993 (225.4)	858 (194.9)	1136 (257.9)	901 (204.6)	714 (162.2)	999 (226.9)	802 (182.1)	976 (221.6)	1025 (232.9)	
i51950	5	25	937 (212.9)	1141 (259.2)	987 (224.2)	1307 (296.7)	1036 (235.0)	820 (186.2)	1149 (260.9)	921 (209.1)	1122 (254.9)	1179 (267.7)	
i51975	5	37.5	1047 (237.7)	1273 (289.1)	1101 (250.0)	1459 (331.3)	1154 (262.1)	915 (207.8)	1282 (291.2)	1026 (233.1)	1251 (284.2)	1314 (298.4)	
061930	6	18	919 (208.5)	1118 (253.9)	967 (219.7)	1279 (290.6)	1014 (230.3)	805 (182.8)	1125 (255.6)	902 (205.0)	1099 (249.6)	1156 (262.6)	
061950	6	30	1056 (239.9)	1285 (291.9)	1111 (252.4)	1472 (334.3)	1165 (264.7)	923 (209.7)	1294 (294.0)	1036 (235.4)	1264 (287.0)	1327 (301.4)	
061975	6	45	1178 (267.7)	1434 (325.6)	1240 (281.7)	1643 (373.1)	1300 (295.3)	1030 (233.9)	1444 (328.0)	1155 (262.4)	1410 (320.3)	1480 (336.2)	
081930	8	24	1205 (273.7)	1467 (333.2)	1268 (288.0)	1679 (381.4)	1331 (302.3)	1055 (239.6)	1477 (335.4)	1185 (269.2)	1443 (327.7)	1517 (344.5)	
081950	8	40	1386 (314.8)	1686 (382.9)	1458 (331.1)	1932 (438.7)	1529 (347.3)	1211 (275.1)	1698 (385.7)	1360 (308.8)	1658 (376.6)	1742 (395.7)	
081975	8	60	1546 (351.3)	1881 (427.3)	1627 (369.6)	2156 (489.7)	1705 (387.3)	1350 (306.7)	1895 (430.5)	1516 (344.3)	1850 (420.3)	1943 (441.3)	
101930	10	30	1492 (338.9)	1817 (412.6)	1571 (356.8)	2079 (472.3)	1649 (374.4)	1307 (296.7)	1830 (415.6)	1467 (333.3)	1790 (405.9)	1877 (426.4)	
101950	10	50	1715 (389.7)	2088 (474.2)	1806 (410.1)	2393 (543.4)	1893 (430.1)	1500 (340.7)	2103 (477.6)	1683 (382.3)	2053 (466.3)	2157 (489.9)	
101975	10	75	1915 (434.9)	2329 (529.0)	2016 (457.9)	2670 (606.4)	2111 (479.5)	1673 (380.0)	2347 (533.0)	1877 (426.2)	2290 (520.3)	2405 (546.2)	
121930	12	36	1780 (404.4)	2166 (492.0)	1874 (425.6)	2479 (563.1)	1965 (446.4)	1557 (353.6)	2180 (495.2)	1749 (397.1)	2131 (484.0)	2238 (508.4)	
121950	12	60	2046 (464.7)	2490 (565.5)	2152 (488.8)	2851 (647.6)	2257 (512.6)	1789 (406.3)	2507 (569.3)	2007 (455.9)	2448 (555.9)	2571 (583.9)	
121975	12	90	2282 (518.4)	2777 (630.6)	2403 (545.7)	3183 (723.0)	2518 (571.8)	1994 (453.0)	2797 (635.3)	2237 (508.2)	2732 (620.5)	2867 (651.2)	

Cooling Towers for Discerning Users™

Thermal Performance Data

Thermal capacities assume 6' (182.88 cm) air inlet.

60 Hz, 50° C.

TTXL Model	Fan Power		Cooling Capacity at Indicated Operating Conditions - GPM										
			(m ³ /hr)										
	No. of Fans	Total Power HP	HWT °F (°C)	93 (33.9)	100 (37.8)	95 (35)	100 (37.8)	93 (33.9)	105 (40.6)	97 (36.1)	95 (35)	100 (37.8)	105 (40.6)
			CWT °F (°C)	83 (28.3)	85 (29.4)	85 (29.4)	85 (29.4)	83 (28.3)	85 (29.4)	87 (30.6)	85 (29.4)	85 (29.4)	85 (29.4)
WBT °F (°C)	76 (24.4)	76 (24.4)	78 (25.6)	78 (25.6)	78 (25.6)	78 (25.6)	78 (25.6)	80 (26.7)	80 (26.7)	80 (26.7)	80 (26.7)		
i21930	2	6	426 (96.8)	413 (93.8)	449 (101.9)	364 (82.6)	356 (80.9)	320 (72.8)	473 (107.4)	375 (85.1)	309 (70.3)	498 (113.1)	
i21950	2	10	490 (111.2)	475 (107.8)	516 (117.2)	418 (94.9)	408 (92.8)	367 (83.4)	544 (123.5)	431 (97.9)	355 (80.7)	573 (130.1)	
i21975	2	15	548 (124.4)	530 (120.4)	577 (131.0)	466 (105.9)	456 (103.6)	409 (93.0)	600 (136.3)	481 (109.3)	395 (89.8)	600 (136.3)	
i31930	3	9	612 (139.0)	593 (134.8)	649 (146.5)	522 (118.7)	511 (116.1)	460 (104.4)	679 (154.3)	538 (122.3)	444 (100.8)	716 (162.6)	
i31950	3	15	704 (159.8)	682 (155.0)	741 (168.3)	600 (136.3)	587 (133.3)	527 (119.7)	781 (177.5)	619 (140.5)	509 (115.7)	822 (186.8)	
i31975	3	22.5	786 (178.5)	761 (172.8)	828 (188.1)	669 (152.0)	654 (148.6)	588 (133.5)	873 (198.3)	691 (156.9)	568 (129.1)	900 (204.4)	
i41930	4	12	796 (180.9)	773 (175.5)	838 (190.4)	680 (154.5)	664 (150.9)	598 (135.9)	884 (200.8)	701 (159.2)	578 (131.2)	932 (211.6)	
i41950	4	20	916 (208.0)	888 (201.7)	964 (219.1)	781 (177.5)	764 (173.4)	687 (156.0)	1017 (230.9)	806 (183.0)	663 (150.5)	1070 (243.0)	
i41975	4	30	1022 (232.2)	991 (225.0)	1077 (244.5)	871 (197.8)	852 (193.6)	764 (173.6)	1135 (257.7)	898 (204.0)	739 (167.9)	1194 (271.3)	
041930	4	12	786 (178.5)	763 (173.2)	828 (188.1)	672 (152.6)	656 (149.0)	591 (134.2)	873 (198.3)	693 (157.3)	571 (129.7)	919 (208.7)	
041950	4	20	904 (205.3)	876 (198.9)	952 (216.3)	771 (175.1)	753 (171.1)	678 (153.9)	1003 (227.8)	795 (180.6)	654 (148.6)	1056 (239.9)	
041975	4	30	1008 (229.0)	977 (221.8)	1063 (241.3)	859 (195.1)	840 (190.8)	754 (171.3)	1120 (254.3)	886 (201.2)	729 (165.6)	1178 (267.5)	
i51930	5	15	1002 (227.5)	971 (220.5)	1055 (239.6)	856 (194.4)	836 (190.0)	752 (170.9)	1112 (252.6)	882 (200.4)	727 (165.1)	1171 (266.0)	
i51950	5	25	1151 (261.5)	1116 (253.4)	1213 (275.5)	982 (223.1)	961 (218.2)	863 (195.9)	1278 (290.2)	1013 (230.1)	834 (189.3)	1345 (305.5)	
i51975	5	37.5	1285 (291.9)	1244 (282.5)	1353 (307.4)	1094 (248.6)	1071 (243.3)	962 (218.4)	1426 (323.9)	1129 (256.4)	929 (211.0)	1500 (340.7)	
061930	6	18	1129 (256.4)	1094 (248.6)	1189 (270.0)	964 (218.8)	941 (213.8)	847 (192.5)	1253 (284.6)	993 (225.6)	819 (185.9)	1320 (299.7)	
061950	6	30	1296 (294.4)	1256 (285.3)	1366 (310.3)	1106 (251.1)	1081 (245.6)	971 (220.5)	1439 (326.9)	1140 (259.0)	938 (213.1)	1515 (344.1)	
061975	6	45	1447 (328.6)	1401 (318.2)	1524 (346.2)	1232 (279.8)	1206 (273.8)	1081 (245.6)	1607 (364.9)	1272 (288.9)	1045 (237.3)	1690 (383.8)	
081930	8	24	1480 (336.2)	1436 (326.0)	1560 (354.3)	1264 (287.2)	1235 (280.6)	1112 (252.6)	1644 (373.4)	1303 (295.9)	1074 (243.9)	1731 (393.1)	
081950	8	40	1702 (386.5)	1649 (374.4)	1793 (407.1)	1450 (329.4)	1418 (322.2)	1275 (289.5)	1889 (429.0)	1496 (339.8)	1231 (279.6)	1988 (451.5)	
081975	8	60	1899 (431.3)	1838 (417.5)	2000 (454.2)	1617 (367.2)	1581 (359.2)	1419 (322.4)	2107 (478.7)	1668 (378.9)	1371 (311.4)	2216 (503.3)	
101930	10	30	1834 (416.5)	1779 (403.9)	1933 (439.0)	1565 (355.5)	1530 (347.5)	1377 (312.6)	2036 (462.3)	1614 (366.6)	1330 (302.1)	2143 (486.7)	
101950	10	50	2107 (478.7)	2042 (463.8)	2220 (504.1)	1796 (408.0)	1757 (399.1)	1578 (358.5)	2340 (531.3)	1853 (420.9)	1524 (346.2)	2460 (558.9)	
101975	10	75	2350 (533.8)	2277 (517.1)	2477 (562.5)	2001 (454.7)	1960 (445.1)	1757 (399.1)	2610 (592.9)	2066 (469.3)	1698 (385.7)	2744 (623.2)	
121930	12	36	2186 (496.5)	2120 (481.4)	2304 (523.2)	1866 (423.9)	1823 (414.1)	1641 (327.7)	2427 (551.3)	1923 (436.8)	1585 (360.0)	2556 (580.5)	
121950	12	60	2511 (570.4)	2434 (552.7)	2647 (601.1)	2141 (486.3)	2094 (475.7)	1881 (427.3)	2788 (633.2)	2208 (501.6)	1817 (412.6)	2934 (666.3)	
121975	12	90	2802 (636.4)	2714 (616.4)	2953 (670.8)	2386 (541.9)	2335 (530.2)	2094 (475.7)	3111 (706.6)	2463 (559.3)	2023 (459.6)	3272 (743.1)	

Cooling Towers for Discerning Users™



Thermal Performance Data

Thermal capacities assume 6' (182.88 cm) air inlet.

50 Hz, 40° C.

TTXL Model	Fan Power		Cooling Capacity at Indicated Operating Conditions - m ³ /hr (GPM)										
			HWT °F (°C)	85 (29.4)	95 (35)	87 (30.6)	90 (32.2)	95 (35)	87 (30.6)	90 (32.2)	95 (35)	92 (33.3)	100 (37.8)
	No. of Fans	Total Power kW	CWT °F (°C)	75 (23.9)	80 (26.7)	77 (25)	80 (26.7)	80 (26.7)	77 (25)	80 (26.7)	80 (26.7)	82 (27.8)	85 (29.4)
			WBT °F (°C)	68 (20)	68 (20)	70 (21.1)	70 (21.1)	70 (21.1)	72 (22.2)	72 (22.2)	72 (22.2)	75 (23.9)	75 (23.9)
i21922	2	4.4	76.6 (337)	101.9 (449)	80.4 (354)	111.2 (490)	94.4 (416)	69.2 (304)	100.0 (440)	85.0 (374)	92.5 (407.4)	108.4 (477)	
i21937	2	7.4	88.8 (391)	117.8 (518)	92.5 (407)	128.0 (564)	108.4 (477)	79.4 (350)	115.0 (506)	98.1 (432)	106.5 (469)	124.3 (547)	
i21956	2	11.2	99.1 (436)	136.3 (600)	103.7 (457)	136.3 (600)	120.6 (531)	88.8 (391)	129.0 (568)	109.3 (481)	118.7 (523)	136.3 (600)	
i31922	3	6.6	110.3 (486)	146.7 (646)	115.9 (510)	159.8 (704)	135.5 (597)	99.1 (436)	143.9 (634)	122.4 (539)	132.7 (584)	155.1 (683)	
i31937	3	11.1	127.1 (560)	169.2 (745)	132.7 (584)	183.2 (807)	155.1 (683)	114.0 (502)	165.4 (728)	141.1 (621)	153.3 (675)	178.5 (786)	
i31956	3	16.8	142.1 (625)	188.8 (831)	148.6 (654)	204.4 (900)	173.8 (765)	127.1 (560)	185.0 (815)	157.0 (691)	171.0 (753)	204.4 (900)	
i41922	4	8.8	143.9 (634)	190.7 (839)	150.5 (662)	207.5 (913)	175.7 (774)	129.0 (568)	186.9 (823)	159.8 (704)	172.9 (761)	201.9 (889)	
i41937	4	14.8	165.4 (728)	219.6 (967)	172.9 (761)	239.3 (1053)	201.9 (889)	147.7 (650)	215.0 (946)	183.2 (807)	199.1 (876)	232.7 (1025)	
i41956	4	22.4	185.0 (815)	245.8 (1082)	193.5 (852)	272.5 (1200)	225.2 (992)	165.4 (728)	240.2 (1058)	204.7 (901)	222.4 (979)	272.5 (1200)	
041922	4	8.8	142.1 (625)	188.8 (831)	148.6 (654)	204.7 (901)	173.8 (765)	127.1 (560)	185.0 (815)	157.9 (695)	171.0 (753)	200.0 (881)	
041937	4	14.8	163.6 (720)	216.8 (955)	171.0 (753)	235.5 (1037)	199.1 (876)	145.8 (642)	212.1 (934)	181.3 (798)	196.3 (864)	229.0 (1008)	
041956	4	22.4	182.2 (802)	242.1 (1066)	190.7 (839)	272.5 (1200)	222.4 (979)	162.6 (716)	237.4 (1045)	201.9 (889)	219.6 (967)	256.1 (1127)	
i51922	5	11	181.3 (798)	240.2 (1058)	189.7 (835)	260.7 (1148)	221.5 (975)	162.6 (716)	235.5 (1037)	200.9 (885)	217.8 (959)	254.2 (1119)	
i51937	5	18.5	208.4 (918)	276.6 (1218)	217.8 (959)	300.0 (1321)	254.2 (1119)	186.0 (819)	271.0 (1193)	230.8 (1016)	250.5 (1103)	292.5 (1288)	
i51956	5	28	231.8 (1020)	308.4 (1358)	243.0 (1070)	340.7 (1500)	283.2 (1247)	207.5 (913)	301.9 (1329)	257.0 (1132)	279.4 (1230)	340.7 (1500)	
061922	6	13.2	203.7 (897)	271.0 (1193)	213.1 (938)	294.4 (1296)	249.5 (1099)	182.2 (802)	265.4 (1169)	226.2 (996)	245.8 (1082)	286.0 (1259)	
061937	6	22.2	234.6 (1033)	311.2 (1370)	244.9 (1078)	338.3 (1489)	286.0 (1259)	209.3 (922)	304.7 (1341)	259.8 (1144)	282.2 (1243)	329.0 (1448)	
061956	6	33.6	261.7 (1152)	347.7 (1531)	273.8 (1206)	377.6 (1662)	319.6 (1407)	233.6 (1029)	340.2 (1498)	289.7 (1276)	314.0 (1383)	367.3 (1617)	
081922	8	17.6	267.3 (1177)	355.1 (1564)	280.4 (1234)	386.0 (1699)	327.1 (1440)	239.3 (1053)	347.7 (1531)	296.3 (1304)	322.4 (1420)	375.7 (1654)	
081937	8	9.6	307.5 (1354)	408.4 (1798)	321.5 (1416)	443.9 (1955)	375.7 (1654)	274.8 (1210)	400.0 (1761)	340.2 (1498)	370.1 (1629)	431.8 (1901)	
081956	8	44.8	343.0 (1510)	456.1 (2008)	358.9 (1580)	495.3 (2180)	418.7 (1843)	306.5 (1350)	446.7 (1967)	379.4 (1671)	413.1 (1819)	481.3 (2119)	
101922	10	22	330.8 (1457)	440.2 (1938)	346.7 (1527)	477.6 (2103)	404.7 (1782)	296.3 (1304)	430.8 (1897)	367.3 (1617)	399.1 (1757)	465.4 (2049)	
101937	10	37	380.4 (1675)	505.6 (2226)	398.1 (1753)	549.5 (2420)	465.4 (2049)	340.2 (1498)	495.3 (2181)	421.5 (1856)	457.9 (2016)	534.6 (2354)	
101956	10	56	424.3 (1868)	564.5 (2485)	444.9 (1959)	614.0 (2703)	518.7 (2284)	379.4 (1671)	553.3 (2436)	470.1 (2070)	511.2 (2251)	596.3 (2625)	
121922	12	26.4	395.3 (1741)	524.3 (2308)	413.1 (1819)	570.1 (2510)	482.2 (2123)	353.3 (1555)	514.0 (2263)	438.3 (1930)	474.8 (2090)	555.1 (2444)	
121937	12	44.4	453.3 (1996)	602.8 (2654)	474.8 (2090)	655.1 (2884)	554.2 (2440)	405.6 (1786)	590.7 (2601)	502.8 (2214)	545.8 (2403)	637.4 (2806)	
121956	12	67.2	506.5 (2230)	672.9 (2963)	529.9 (2333)	731.8 (3222)	618.7 (2724)	452.3 (1992)	658.9 (2901)	560.7 (2469)	609.3 (2683)	711.2 (3131)	

Cooling Towers for Discerning Users™

Thermal Performance Data 50 Hz, 40° C. Continued on Page 18

Thermal Performance Data

Thermal capacities assume 6' (182.88 cm) air inlet.

50 Hz, 40° C.

TTXL Model	Fan Power		Cooling Capacity at Indicated Operating Conditions - m ³ /hr (GPM)										
			HWT °F (°C)	93 (33.9)	100 (37.8)	95 (35)	100 (37.8)	93 (33.9)	105 (40.6)	97 (36.1)	95 (35)	100 (37.8)	105 (40.6)
	No. of Fans	Total Power kW	CWT °F (°C)	83 (28.3)	85 (29.4)	85 (29.4)	85 (29.4)	83 (28.3)	85 (29.4)	87 (30.6)	85 (29.4)	85 (29.4)	90 (32.2)
			WBT °F (°C)	76 (24.4)	76 (24.4)	78 (25.6)	78 (25.6)	78 (25.6)	78 (25.6)	80 (26.7)	80 (26.7)	80 (26.7)	80 (26.7)
i21922	2	4.4	79.4 (350)	83.2 (366)	97.2 (428)	87.9 (387)	83.2 (366)	75.7 (333)	106.5 (469)	87.9 (387)	76.6 (337)	83.2 (366)	
i21937	2	7.4	91.6 (403)	96.3 (424)	111.2 (490)	100.9 (444)	96.3 (424)	86.9 (383)	122.4 (539)	100.9 (444)	87.9 (387)	95.3 (420)	
i21956	2	11.2	101.9 (449)	107.5 (473)	124.3 (547)	112.1 (494)	106.5 (469)	97.2 (428)	136.3 (600)	112.1 (494)	97.2 (428)	106.5 (469)	
i31922	3	6.6	114.0 (502)	120.6 (531)	139.3 (613)	126.2 (556)	119.6 (527)	109.3 (481)	153.3 (675)	125.2 (551)	109.3 (481)	119.6 (527)	
i31937	3	11.1	130.8 (576)	138.3 (609)	160.7 (708)	144.9 (638)	137.4 (605)	125.2 (551)	176.6 (778)	143.9 (634)	125.2 (551)	137.4 (605)	
i31956	3	16.8	146.7 (646)	154.2 (679)	179.4 (790)	161.7 (712)	153.3 (675)	139.3 (613)	204.4 (900)	160.7 (708)	140.2 (617)	152.3 (671)	
i41922	4	8.8	148.6 (654)	156.1 (687)	181.3 (798)	164.5 (724)	156.1 (687)	142.1 (625)	199.1 (876)	163.6 (720)	142.1 (625)	155.1 (683)	
i41937	4	14.8	171.0 (753)	179.4 (790)	208.4 (918)	188.8 (831)	178.5 (786)	162.6 (716)	229.0 (1008)	187.9 (827)	163.6 (720)	178.5 (786)	
i41956	4	22.4	190.7 (839)	200.0 (881)	232.7 (1025)	210.3 (926)	200.0 (881)	181.3 (798)	256.1 (1127)	209.3 (922)	182.2 (802)	199.1 (876)	
041922	4	8.8	146.7 (646)	154.2 (679)	179.4 (790)	161.7 (712)	154.2 (679)	140.2 (617)	197.2 (868)	161.7 (712)	140.2 (617)	153.3 (675)	
041937	4	14.8	168.2 (741)	177.6 (782)	205.6 (905)	186.0 (819)	176.6 (778)	160.7 (708)	226.2 (996)	185.0 (815)	161.7 (712)	175.7 (774)	
041956	4	22.4	187.9 (827)	197.2 (868)	229.9 (1012)	207.5 (913)	197.2 (868)	179.4 (790)	252.3 (1111)	206.5 (909)	179.4 (790)	196.3 (864)	
i51922	5	11	186.9 (823)	196.3 (864)	228.0 (1004)	206.5 (909)	196.3 (864)	178.5 (786)	251.4 (1107)	205.6 (905)	179.4 (790)	195.3 (860)	
i51937	5	18.5	215.0 (946)	225.2 (992)	262.6 (1156)	236.4 (1041)	225.2 (992)	204.7 (901)	287.9 (1267)	236.4 (1041)	205.6 (905)	224.3 (988)	
i51956	5	28	239.3 (1053)	251.4 (1107)	292.5 (1288)	264.5 (1164)	251.4 (1107)	228.0 (1004)	340.7 (1500)	263.6 (1160)	229.0 (1008)	249.5 (1099)	
061922	6	13.2	210.3 (926)	221.5 (975)	257.0 (1132)	232.7 (1025)	220.6 (971)	200.9 (885)	282.2 (1243)	231.8 (1020)	201.9 (889)	219.6 (967)	
061937	6	22.2	241.1 (1062)	254.2 (1119)	295.3 (1300)	266.4 (1173)	253.3 (1115)	230.8 (1016)	324.3 (1428)	266.4 (1173)	230.8 (1016)	252.3 (1111)	
061956	6	33.6	269.2 (1185)	283.2 (1247)	329.9 (1453)	297.2 (1309)	282.2 (1243)	257.0 (1132)	362.6 (1597)	296.3 (1304)	257.9 (1136)	281.3 (1239)	
081922	8	17.6	275.7 (1214)	290.7 (1280)	337.4 (1485)	304.7 (1341)	289.7 (1276)	263.6 (1160)	371.0 (1634)	303.7 (1337)	264.5 (1164)	288.8 (1271)	
081937	8	9.6	316.8 (1395)	333.6 (1469)	387.9 (1708)	349.5 (1539)	332.7 (1465)	302.8 (1333)	426.2 (1876)	348.6 (1535)	303.7 (1337)	330.8 (1457)	
081956	8	44.8	353.3 (1555)	372.0 (1638)	432.7 (1905)	389.7 (1716)	371.0 (1634)	337.4 (1485)	475.7 (2094)	388.8 (1712)	338.3 (1490)	369.2 (1625)	
101922	10	22	342.1 (1506)	359.8 (1584)	417.8 (1839)	377.6 (1662)	358.9 (1580)	327.1 (1440)	459.8 (2024)	376.6 (1658)	328.0 (1444)	357.9 (1576)	
101937	10	37	392.5 (1728)	413.1 (1819)	480.4 (2115)	433.6 (1909)	412.1 (1815)	374.8 (1650)	528.0 (2325)	431.8 (1901)	375.7 (1654)	410.3 (1806)	
101956	10	56	437.4 (1926)	459.8 (2024)	535.5 (2358)	483.2 (2127)	458.9 (2020)	416.8 (1835)	588.8 (2592)	481.3 (2119)	418.7 (1843)	457.0 (2012)	
121922	12	26.4	407.4 (1794)	429.0 (1889)	498.1 (2193)	450.5 (1983)	427.1 (1880)	389.7 (1716)	547.7 (2411)	448.6 (1975)	390.7 (1720)	426.2 (1876)	
121937	12	44.4	468.2 (2062)	492.5 (2169)	572.0 (2518)	516.8 (2276)	490.7 (2160)	446.7 (1967)	629.0 (2769)	515.0 (2267)	447.7 (1971)	488.8 (2152)	
121956	12	67.2	521.5 (2296)	548.6 (2415)	638.3 (2810)	575.7 (2535)	547.7 (2411)	497.2 (2189)	701.9 (3090)	573.8 (2527)	499.1 (2197)	544.9 (2399)	

Cooling Towers for Discerning Users™



TTXL Model	Fan Power		Cooling Capacity at Indicated Operating Conditions - m ³ /hr (GPM)										
			HWT °F (°C)	85 (29.4)	95 (35)	87 (30.6)	90 (32.2)	95 (35)	87 (30.6)	90 (32.2)	95 (35)	92 (33.3)	100 (37.8)
	No. of Fans	Total Power kW	CWT °F (°C)	75 (23.9)	80 (26.7)	77 (25)	80 (26.7)	80 (26.7)	77 (25)	80 (26.7)	80 (26.7)	82 (27.8)	85 (29.4)
			WBT °F (°C)	68 (20)	68 (20)	70 (21.1)	70 (21.1)	70 (21.1)	72 (22.2)	72 (22.2)	72 (22.2)	75 (23.9)	75 (23.9)
i21929	2	5.8	83.2 (366)	110.3 (486)	86.9 (383)	120.6 (531)	101.9 (449)	74.8 (329)	108.4 (477)	92.5 (407)	100.0 (440)	116.8 (514)	
i21945	2	8.8	93.5 (411)	123.4 (543)	97.2 (428)	136.3 (600)	114.0 (502)	83.2 (366)	120.6 (531)	102.8 (453)	112.1 (494)	136.3 (600)	
i31929	3	8.7	119.6 (527)	158.9 (700)	125.2 (551)	172.9 (761)	145.8 (642)	107.5 (473)	156.1 (687)	132.7 (584)	143.9 (634)	168.2 (741)	
i31945	3	13.2	133.6 (588)	177.6 (782)	140.2 (617)	204.4 (900)	163.6 (720)	119.6 (527)	173.8 (765)	147.7 (650)	160.7 (708)	187.9 (827)	
i41929	4	11.6	156.1 (687)	206.5 (909)	162.6 (716)	224.3 (987)	190.7 (839)	139.3 (613)	202.8 (893)	172.9 (761)	186.9 (823)	218.7 (963)	
i41945	4	17.6	173.8 (765)	230.8 (1016)	182.2 (802)	251.4 (1106)	212.1 (934)	155.1 (683)	226.2 (996)	192.5 (848)	209.3 (922)	243.9 (1074)	
041929	4	11.6	153.3 (675)	203.7 (897)	160.7 (708)	221.5 (975)	187.9 (827)	137.4 (605)	200.0 (881)	170.1 (749)	185.0 (815)	215.9 (951)	
041945	4	17.6	172.0 (757)	228.0 (1004)	179.4 (790)	247.7 (1090)	209.3 (922)	153.3 (675)	223.4 (983)	189.7 (835)	206.5 (909)	241.1 (1062)	
i51929	5	14.5	195.3 (860)	259.8 (1144)	204.7 (901)	282.2 (1243)	239.3 (1053)	175.7 (774)	254.2 (1119)	216.8 (955)	235.5 (1037)	274.8 (1210)	
i51945	5	22	218.7 (963)	290.7 (1280)	229.0 (1008)	315.9 (1391)	267.2 (1177)	195.3 (860)	284.1 (1251)	242.1 (1066)	262.6 (1156)	306.5 (1350)	
061929	6	17.4	220.6 (971)	292.5 (1288)	230.8 (1016)	318.7 (1403)	269.2 (1185)	197.2 (868)	286.9 (1263)	243.9 (1074)	265.4 (1169)	309.3 (1362)	
061945	6	26.4	245.8 (1082)	327.1 (1440)	257.9 (1136)	355.1 (1564)	300.9 (1325)	220.6 (971)	320.6 (1411)	272.9 (1202)	296.3 (1304)	345.8 (1522)	
081929	8	23.2	288.8 (1271)	384.1 (1691)	302.8 (1333)	417.8 (1839)	353.3 (1555)	258.9 (1140)	376.7 (1658)	320.6 (1411)	347.7 (1531)	406.5 (1790)	
081945	8	35.2	322.4 (1420)	429.0 (1889)	338.3 (1490)	466.4 (2053)	394.4 (1736)	288.8 (1271)	420.6 (1852)	357.9 (1576)	388.8 (1712)	453.3 (1996)	
101929	10	29	357.9 (1576)	475.7 (2094)	374.8 (1650)	516.8 (2276)	437.4 (1926)	320.6 (1411)	466.4 (2053)	397.2 (1749)	430.8 (1897)	503.7 (2218)	
101945	10	44	400.0 (1761)	531.8 (2341)	418.7 (1843)	577.6 (2543)	488.8 (2152)	357.9 (1576)	520.6 (2292)	443.0 (1950)	481.3 (2119)	561.7 (2473)	
121929	12	34.8	427.1 (1880)	567.3 (2498)	446.7 (1967)	616.8 (2716)	521.5 (2296)	382.2 (1683)	556.1 (2448)	473.8 (2086)	514.0 (2263)	600.0 (2642)	
121945	12	52.8	476.6 (2099)	633.6 (2790)	499.1 (2197)	688.8 (3033)	582.2 (2564)	426.2 (1876)	620.6 (2732)	528.0 (2325)	573.8 (2527)	670.1 (2950)	

Thermal Performance Data 50 Hz, 50° C. Continued on Page 20

The thermal performance of the TTXL Series cooling towers is certified by the Cooling Technology Institute in accordance with its standard STD-201 and has been assigned CTI certification validation number 08-17-06. This certification is your assurance that the proposed capacities accurately reflect actual cooling tower performance. CTI certification under STD-201 is limited to thermal operating conditions with entering wet bulbs between 55°F and 90°F (12.8°C and 32.2°C), a maximum process fluid temperature of 125°F (51.7°C), a cooling range of 4°F (2.2°C) or greater, and a cooling approach of 5°F (2.8°C) or greater.



Thermal Performance Data

Thermal capacities assume 6' (182.88 cm) air inlet.

50 Hz, 50° C.

TTXL Model	Fan Power		Cooling Capacity at Indicated Operating Conditions - m ³ /hr (GPM)										
			HWT °F (°C)	93 (33.9)	100 (37.8)	95 (35)	100 (37.8)	93 (33.9)	105 (40.6)	97 (36.1)	95 (35)	100 (37.8)	105 (40.6)
	No. of Fans	Total Power kW	CWT °F (°C)	83 (28.3)	85 (29.4)	85 (29.4)	85 (29.4)	83 (28.3)	85 (29.4)	87 (30.6)	85 (29.4)	85 (29.4)	90 (32.2)
			WBT °F (°C)	76 (24.4)	76 (24.4)	78 (25.6)	78 (25.6)	78 (25.6)	78 (25.6)	80 (26.7)	80 (26.7)	80 (26.7)	80 (26.7)
i21929	2	5.8	86.0 (379)	90.7 (399)	104.7 (461)	95.3 (420)	90.7 (399)	82.2 (362)	115.9 (510)	94.4 (416)	82.2 (362)	89.7 (395)	
i21945	2	8.8	96.3 (424)	100.9 (444)	117.89 (518)	105.6 (465)	100.9 (444)	91.6 (403)	136.3 (600)	105.6 (465)	91.6 (403)	100.0 (440)	
i31929	3	8.7	123.4 (543)	129.9 (572)	151.4 (667)	136.4 (601)	129.9 (572)	117.8 (518)	166.4 (732)	135.5 (597)	118.7 (523)	129.0 (568)	
i31945	3	13.2	137.4 (605)	144.9 (638)	168.2 (741)	152.3 (671)	144.9 (638)	131.8 (580)	185.0 (815)	151.4 (667)	131.8 (580)	143.9 (634)	
i41929	4	11.6	160.7 (708)	169.2 (745)	196.3 (864)	177.6 (166)	168.2 (741)	153.3 (675)	215.9 (951)	176.6 (778)	154.2 (679)	168.2 (741)	
i41945	4	17.6	179.4 (790)	188.8 (831)	219.6 (967)	198.1 (872)	187.9 (827)	171.0 (753)	241.1 (1062)	197.2 (868)	172.0 (757)	186.9 (823)	
041929	4	11.6	158.9 (700)	167.3 (737)	193.5 (852)	174.8 (769)	166.4 (732)	151.4 (667)	213.1 (938)	174.8 (769)	152.3 (671)	165.4 (728)	
041945	4	17.6	176.6 (778)	186.0 (819)	215.9 (951)	195.3 (860)	186.0 (819)	169.2 (745)	237.4 (1045)	194.4 (856)	169.1 (745)	185.0 (815)	
i51929	5	14.5	201.9 (889)	212.1 (934)	246.8 (1086)	223.4 (983)	212.1 (934)	193.5 (852)	271.0 (1193)	222.4 (979)	193.5 (852)	211.2 (930)	
i51945	5	22	225.2 (992)	237.4 (1045)	275.7 (1214)	248.6 (1095)	236.4 (1041)	215.0 (946)	302.8 (1333)	247.7 (1090)	215.9 (951)	235.5 (1037)	
061929	6	17.4	227.1 (1000)	239.3 (1053)	278.5 (122.6)	251.4 (1107)	238.3 (1049)	216.8 (955)	305.6 (1346)	250.5 (1103)	217.8 (959)	237.4 (1045)	
061945	6	26.4	253.3 (1115)	267.3 (1177)	310.3 (1366)	280.4 (1234)	266.4 (1173)	242.1 (1066)	341.1 (1502)	279.4 (1230)	243.0 (1070)	264.5 (1164)	
081929	8	23.2	298.1 (1313)	314.0 (1383)	364.5 (1605)	329.9 (1453)	313.1 (1378)	285.0 (1255)	400.9 (1765)	328.0 (1444)	286.0 (1259)	312.1 (1374)	
081945	8	35.2	332.7 (1465)	350.5 (1543)	407.5 (1794)	367.3 (1617)	349.5 (1539)	317.8 (1399)	447.7 (1971)	366.4 (1613)	318.7 (1403)	347.7 (1531)	
101929	10	29	369.2 (1625)	388.8 (1712)	451.4 (1987)	408.4 (1798)	387.9 (1708)	353.3 (1555)	496.3 (2185)	406.5 (1790)	354.2 (1560)	386.0 (1699)	
101945	10	44	412.1 (1815)	433.6 (1909)	504.7 (2222)	455.1 (2004)	432.7 (1905)	393.5 (1732)	554.2 (2440)	453.3 (1996)	394.4 (1736)	430.8 (1897)	
121929	12	34.8	441.1 (1942)	463.6 (2041)	538.3 (2370)	486.0 (2140)	462.6 (2037)	420.6 (1852)	592.5 (2609)	485.0 (2136)	421.5 (1856)	460.7 (2029)	
121945	12	52.8	491.6 (2164)	516.8 (2276)	600.9 (2646)	542.1 (2387)	515.9 (2271)	468.2 (2062)	660.7 (2909)	541.1 (2382)	470.1 (2070)	513.1 (2259)	

The thermal performance of the TTXL Series cooling towers is certified by the Cooling Technology Institute in accordance with its standard STD-201 and has been assigned CTI certification validation number 08-17-06. This certification is your assurance that the proposed capacities accurately reflect actual cooling tower performance. CTI certification under STD-201 is limited to thermal operating conditions with entering wet bulbs between 55°F and 90°F (12.8°C and 32.2°C), a maximum process fluid temperature of 125°F (51.7°C), a cooling range of 4°F (2.2°C) or greater, and a cooling approach of 5°F (2.8°C) or greater.



Sub-Structure/Multiple Modules % Capability Correction (3 HP / 2.2 kW Models)

Inlet Ht (ft)	% Capability Correction (3 HP / 2.2 kW Models)									
	1	2	3	4	5	6	7	8	9	10
021930										
4	0.998	0.993	0.988	0.984	0.981	0.978	0.976	0.973	0.972	0.970
6	1.000	0.998	0.996	0.994	0.993	0.991	0.990	0.990	0.989	0.988
8	1.000	1.000	0.998	0.997	0.997	0.996	0.995	0.995	0.994	0.994
10	1.001	1.001	0.999	0.999	0.998	0.998	0.998	0.997	0.997	0.997
12	1.002	1.001	1.001	1.000	0.999	0.999	0.999	0.999	0.998	0.998
031930										
4	0.998	0.991	0.985	0.978	0.973	0.967	0.972	0.959	0.956	0.953
6	1.000	0.997	0.994	0.992	0.989	0.986	0.985	0.983	0.981	0.980
8	1.000	0.999	0.997	0.995	0.995	0.993	0.992	0.991	0.990	0.990
10	1.001	1.000	0.999	0.998	0.997	0.996	0.995	0.995	0.994	0.994
12	1.001	1.001	0.999	0.999	0.998	0.998	0.997	0.997	0.997	0.996
041930										
4	0.997	0.991	0.987	0.985	0.983	0.982	0.981	0.980	0.979	0.978
6	1.000	0.998	0.996	0.995	0.994	0.993	0.993	0.992	0.992	0.992
8	1.001	1.000	0.999	0.998	0.998	0.998	0.997	0.997	0.997	0.997
10	1.002	1.001	1.001	1.000	0.999	0.999	0.999	0.999	0.999	0.999
12	1.002	1.002	1.001	1.001	1.001	1.001	1.001	1.001	1.000	1.000
051930										
4	0.998	0.989	0.978	0.968	0.958	0.948	0.947	0.932	0.926	0.919
6	1.000	0.996	0.992	0.987	0.982	0.978	0.974	0.970	0.966	0.964
8	1.001	1.999	0.996	0.998	0.991	0.988	0.986	0.984	0.982	0.980
10	1.002	1.000	0.998	0.996	0.995	0.993	0.992	0.991	0.989	0.988
12	1.002	1.000	1.000	0.998	0.997	0.996	0.995	0.994	0.993	0.992
061930										
4	0.996	0.987	0.980	0.975	0.971	0.968	0.966	0.964	0.962	0.961
6	1.000	0.996	0.993	0.991	0.989	0.988	0.987	0.986	0.985	0.984
8	1.001	0.999	0.997	0.996	0.996	0.995	0.994	0.994	0.993	0.993
10	1.002	1.001	1.000	0.999	0.998	0.998	0.998	0.997	0.997	0.997
12	1.003	1.002	1.001	1.001	1.000	0.999	0.999	0.999	0.999	0.999
081930										
4	0.995	0.983	0.974	0.966	0.960	0.955	0.951	0.947	0.944	0.942
6	1.000	0.994	0.990	0.986	0.984	0.981	0.979	0.978	0.976	0.975
8	1.002	0.998	0.996	0.994	0.992	0.991	0.990	0.989	0.988	0.987
10	1.002	1.001	0.999	0.998	0.996	0.996	0.995	0.994	0.994	0.994
12	1.003	1.002	1.001	0.999	0.999	0.998	0.998	0.997	0.997	0.996
101930										
4	0.995	0.981	0.968	0.958	0.949	0.942	0.936	0.931	0.927	0.923
6	1.000	0.994	0.988	0.983	0.979	0.975	0.973	0.970	0.968	0.966
8	1.002	0.998	0.995	0.992	0.990	0.988	0.986	0.985	0.983	0.982
10	1.003	1.001	0.998	0.996	0.995	0.993	0.992	0.992	0.990	0.990
12	1.004	1.002	1.000	0.999	0.998	0.997	0.996	0.995	0.995	0.994
121930										
4	0.994	0.978	0.962	0.949	0.938	0.929	0.821	0.915	0.909	0.904
6	1.000	0.992	0.985	0.979	0.973	0.969	0.965	0.961	0.959	0.956
8	1.002	0.998	0.994	0.990	0.987	0.984	0.982	0.980	0.979	0.976
10	1.003	1.000	0.997	0.995	0.993	0.991	0.990	0.988	0.987	0.986
12	1.003	1.001	0.999	0.998	0.996	0.995	0.994	0.993	0.992	0.992

Sub-Structure/Multiple Modules % Capability Correction (4 HP & 5 HP / 2.9 & 3.7 kW Models)

Inlet Ht (ft)	% Capability Correction (4 HP & 5 HP / 2.9 & 3.7 kW Models)									
	1	2	3	4	5	6	7	8	9	10
021950										
4	0.998	0.993	0.989	0.985	0.981	0.979	0.976	0.974	0.973	0.971
6	1.000	0.998	0.996	0.994	0.993	0.992	0.991	0.990	0.989	0.989
8	1.001	0.999	0.998	0.998	0.997	0.996	0.995	0.995	0.995	0.994
10	1.001	1.000	1.000	0.999	0.999	0.998	0.998	0.997	0.997	0.997
12	1.001	1.001	1.000	1.000	1.000	0.999	0.999	0.999	0.999	0.999
031950										
4	0.998	0.992	0.985	0.979	0.973	0.969	0.965	0.961	0.958	0.954
6	1.000	0.997	0.994	0.992	0.989	0.987	0.985	0.984	0.982	0.981
8	1.000	0.999	0.997	0.996	0.995	0.993	0.992	0.992	0.991	0.990
10	1.001	1.000	0.999	0.998	0.997	0.996	0.996	0.995	0.995	0.994
12	1.001	1.001	1.000	1.000	0.999	0.998	0.998	0.997	0.997	0.997
041950										
4	0.997	0.991	0.988	0.985	0.983	0.982	0.981	0.980	0.979	0.979
6	1.000	0.998	0.996	0.995	0.994	0.993	0.993	0.993	0.992	0.992
8	1.001	1.000	0.999	0.998	0.998	0.998	0.997	0.997	0.997	0.997
10	1.002	1.001	1.000	1.000	1.000	1.000	1.000	1.000	0.999	0.999
12	1.002	1.001	1.001	1.001	1.001	1.000	1.000	1.000	1.000	1.000
051950										
4	0.998	0.989	0.979	0.969	0.959	0.950	0.942	0.934	0.928	0.922
6	1.000	0.996	0.991	0.987	0.983	0.978	0.974	0.971	0.968	0.965
8	1.001	0.999	0.996	0.994	0.991	0.989	0.987	0.984	0.983	0.981
10	1.002	1.000	0.998	0.996	0.995	0.993	0.992	0.991	0.989	0.988
12	1.002	1.000	1.000	0.998	0.997	0.996	0.995	0.994	0.993	0.992
061950										
4	0.996	0.988	0.981	0.976	0.972	0.969	0.967	0.965	0.963	0.963
6	1.000	0.996	0.994	0.991	0.989	0.988	0.987	0.986	0.985	0.985
8	1.001	1.000	0.998	0.996	0.995	0.994	0.994	0.994	0.993	0.993
10	1.003	1.001	1.000	0.999	0.998	0.998	0.997	0.997	0.997	0.997
12	1.003	1.002	1.001	1.001	1.000	1.000	0.999	0.999	0.999	0.999
081950										
4	0.996	0.984	0.975	0.967	0.961	0.956	0.952	0.949	0.946	0.944
6	1.000	0.995	0.990	0.987	0.984	0.982	0.980	0.979	0.977	0.976
8	1.002	0.999	0.996	0.994	0.993	0.991	0.990	0.989	0.989	0.988
10	1.003	1.001	0.999	0.997	0.996	0.996	0.995	0.994	0.994	0.994
12	1.003	1.002	1.001	0.999	0.999	0.998	0.998	0.997	0.997	0.997
101950										
4	0.996	0.981	0.969	0.959	0.950	0.944	0.938	0.933	0.929	0.926
6	1.000	0.994	0.989	0.984	0.980	0.976	0.973	0.971	0.969	0.967
8	1.002	0.998	0.996	0.992	0.990	0.989	0.987	0.985	0.984	0.983
10	1.003	1.001	0.998	0.996	0.995	0.993	0.992	0.992	0.991	0.990
12	1.003	1.002	1.000	0.998	0.997	0.997	0.996	0.995	0.995	0.994
121950										
4	0.994	0.978	0.963	0.950	0.938	0.930	0.922	0.915	0.910	0.905
6	1.000	0.992	0.985	0.979	0.974	0.969	0.965	0.962	0.959	0.956
8	1.002	0.997	0.994	0.990	0.987	0.984	0.981	0.979	0.978	0.976
10	1.003	1.000	0.997	0.995	0.993	0.991	0.990	0.988	0.987	0.986
12	1.003	1.001	0.999	0.998	0.996	0.995	0.994	0.993	0.992	0.992

Sub-Structure/Multiple Modules % Capability Correction (6 & 7.5 HP / 4.5 & 5.6 kW Models)

Inlet Ht (ft)	% Capability Correction (6 & 7.5 HP / 4.5 & 5.6 kW Models)									
	1	2	3	4	5	6	7	8	9	10
021975										
4	0.998	0.994	0.989	0.985	0.982	0.979	0.977	0.974	0.973	0.972
6	1.000	0.998	0.996	0.994	0.993	0.992	0.991	0.990	0.989	0.989
8	1.000	1.000	0.998	0.998	0.997	0.996	0.996	0.995	0.995	0.994
10	1.001	1.000	0.999	0.999	0.998	0.998	0.998	0.998	0.997	0.997
12	1.001	1.001	1.000	1.000	0.999	0.999	0.999	0.999	0.998	0.998
031975										
4	0.998	0.992	0.985	0.979	0.974	0.969	0.965	0.961	0.958	0.956
6	1.000	0.998	0.995	0.992	0.990	0.988	0.985	0.984	0.983	0.981
8	1.000	0.999	0.998	0.996	0.995	0.994	0.993	0.961	0.991	0.990
10	1.001	1.000	0.999	0.998	0.997	0.997	0.996	0.995	0.995	0.995
12	1.001	1.000	1.000	0.999	0.999	0.998	0.998	0.997	0.997	0.997
041975										
4	0.997	0.991	0.988	0.986	0.984	0.983	0.981	0.980	0.980	0.979
6	1.000	0.998	0.996	0.995	0.994	0.994	0.993	0.993	0.993	0.992
8	1.001	1.000	0.999	0.998	0.998	0.997	0.997	0.997	0.997	0.997
10	1.002	1.001	1.000	1.000	1.000	1.000	0.857	0.999	0.999	0.999
12	1.002	1.002	1.001	1.001	1.001	1.001	1.001	1.000	1.000	1.000
051975										
4	0.998	0.989	0.979	0.969	0.960	0.951	0.942	0.935	0.929	0.923
6	1.000	0.996	0.992	0.987	0.983	0.979	0.975	0.972	0.968	0.965
8	1.001	0.999	0.996	0.993	0.991	0.989	0.987	0.985	0.983	0.981
10	1.002	1.000	0.998	0.996	0.995	0.993	0.992	0.991	0.989	0.988
12	1.002	1.000	1.000	0.998	0.997	0.996	0.995	0.994	0.993	0.992
061975										
4	0.996	0.988	0.981	0.977	0.973	0.971	0.968	0.966	0.964	0.964
6	1.000	0.997	0.994	0.991	0.990	0.988	0.988	0.987	0.986	0.985
8	1.002	1.000	0.998	0.997	0.996	0.995	0.995	0.994	0.994	0.993
10	1.002	1.001	1.000	0.999	0.998	0.998	0.997	0.997	0.997	0.997
12	1.003	1.002	1.001	1.000	1.000	1.000	0.999	0.999	0.999	0.999
081975										
4	0.995	0.984	0.975	0.968	0.962	0.957	0.953	0.950	0.947	0.945
6	1.000	0.995	0.991	0.987	0.984	0.982	0.980	0.979	0.977	0.976
8	1.002	0.998	0.996	0.995	0.993	0.991	0.991	0.989	0.989	0.988
10	1.002	1.000	0.999	0.998	0.997	0.996	0.995	0.994	0.994	0.994
12	1.003	1.001	1.000	1.000	0.999	0.998	0.998	0.998	0.997	0.997
101975										
4	0.995	0.982	0.970	0.960	0.952	0.944	0.939	0.934	0.930	0.927
6	1.000	0.994	0.988	0.983	0.979	0.976	0.973	0.971	0.969	0.967
8	1.002	0.998	0.995	0.992	0.990	0.988	0.987	0.985	0.984	0.983
10	1.003	1.000	0.999	0.997	0.995	0.994	0.993	0.992	0.991	0.991
12	1.003	1.002	1.000	0.999	0.998	0.997	0.996	0.996	0.995	0.995
121975										
4	0.995	0.979	0.964	0.951	0.940	0.932	0.924	0.918	0.913	0.908
6	1.000	0.993	0.986	0.980	0.974	0.970	0.966	0.963	0.900	0.958
8	1.002	0.998	0.994	0.990	0.987	0.984	0.982	0.980	0.970	0.977
10	1.003	1.000	0.997	0.995	0.993	0.991	0.990	0.988	0.987	0.986
12	1.003	1.001	0.999	0.998	0.996	0.995	0.994	0.993	0.992	0.992

OPTIONAL EQUIPMENT

Motor Pre-Wire

TTXL Series Modular Cooling Towers™ are shipped with motors factory pre-wired to a central junction box (NEMA-4X). Motors can be factory pre-wired to individual “lock-out/tag-out” rotary disconnect switches. Motor wiring used is Alpha brand shielded 12-4 AWG oil resistant, VFD compatible, liquid tight flexible cable.

Sub-Structure Kits

Each Modular Cooling Tower has a 1-foot (30.5 cm) high stub leg kit for mounting on customer furnished support structure. As an option, towers can be furnished with leg kits from 4 feet to 12 feet (121.9 cm to 365.8 cm) in height. The most common configuration uses 6-foot (182.88 cm) high legs to allow convenient access to the fan inlet of the tower for inspections and maintenance. Sub-structure kits include FRP legs with integrated footpads (Nylon), angle braces (FRP), and stainless steel assembly

Control Panels

Panels are high quality, UL rated, NEMA 4 enclosures (epoxy painted steel) equipped for single-point wiring to a manual disconnect. Each control panel includes power distribution to individual motor starters with lockout disconnect, magnetic overload protection, and solid-state adjustable thermal overload protection. There is a door mounted H-O-A switch and RUN pilot light for each motor starter. Auxiliary motor starter contacts can be provided. A solid-state PLC is provided for supply water temperature control with a door-mounted operator interface display panel and an RTD temperature sensor for remote mounting in the customer’s tower discharge piping.

Standard water temperature control is done with fan staging through the pre-programmed PLC.

Variable Frequency Drives

Optional water temperature control can be done with a remote mounted variable frequency drive (VFD) suitable for multiple motor operation. The VFD output is wired to the control panel disconnect switch. The output frequency of the VFD can be controlled through the pre-programmed PLC by means of a 4-20 ma or 0-24V analog output. If the VFD is bypassed for any reason, the PLC returns to fan staging control.

Operating Tower Tech cooling tower fans through a VFD provides the tightest temperature control possible at the very lowest energy consumption. When operated with variable water flow, the combination of the VFD and the variable flow Rotary Spray Nozzle™ provide energy saving opportunities that no other cooling tower can match. Contact your Tower Tech sales representative for details.

Basin Heaters

Stainless steel electric immersion heaters are recommended when operating in low ambient temperature conditions in order to protect against basin freezing when the tower is shut down. A NEMA 4X control panel is provided to control up to four individual elements (6 kW each). A remote temperature sensor is provided for mounting in the tower basin and the controller is preset to 45°F (7.2°C). All heating elements must be located within the same tower water basin as the sensing element. Threaded flanges are installed in the tower’s cold water basin for mounting each heating element and the temperature sensor. The control panel must be field mounted and wired to each heating element and the temperature sensor. A power source separate from the cooling tower fans is recommended.

Level Control

When water level control is needed in the TTXL tower module, the standard level controller is a mechanical valve actuated through a float mounted on a short rod located in the external sump container which is attached to the terminal end of each tower module. To function correctly, the mechanical float valve requires inlet water pressure of 25 psi (or less) applied at the valve inlet. The use of a pressure reducing valve (PRV) is necessary when the inlet water supply exceeds 25 psi.

If a non-contact water level control is desired, a pre-engineered, self-contained ultrasonic liquid level control package is optionally available. The package consists of a continuous measuring ultrasonic device combined with a controlling relay, an LCD screen, and a stilling well mounting pipe. The stilling well pipe is mounted in the tower’s equalization/overflow piping. The ultrasonic device operates on an analog 4-20ma circuit to the relay/LCD which sends command signals to the solenoid valve (solenoid valve not supplied). The LCD screen shows the water level and the indicator lights show whether the solenoid valve is commanded ON or OFF.

Seawater Applications

Tower Tech modules are the best solution available for cooling with seawater. All of the structural and internal components are inert in the presence of seawater. Even 304 Stainless Steel is aggressively attacked and corroded by the chlorides in seawater. Tower Tech offers a wide selection of fouling resistant fills and a 316 Stainless Steel hardware option to assure long life and low maintenance for your operations. There will be a 5-15% thermal capacity (gpm) derate depending on the salinity content of the cooling water. Contact your Tower Tech representative for solutions to match your specific application.

Engineering Certifications

Certified calculations are available for all models with substructures up to 8 feet (243.8 cm) for seismic and wind loading in accordance with the International Building Code's most severe requirements. Sustained wind loading at 150 MPH/41 psf (241.4 KPH/200 KSM) for hurricane exposure and IBC seismic force factor $C_s=0.4 \times$ weight, category D ($S_s=200$, $S_1=150$, soil class E).

Tower Tech has performed extensive acoustic testing in accordance with CTI Standard ATC-128 using licensed Acoustical Engineers. Sound data for all Tower Tech models is available. Computer simulated site specific 3D sound modeling is also available through your Tower Tech representative.

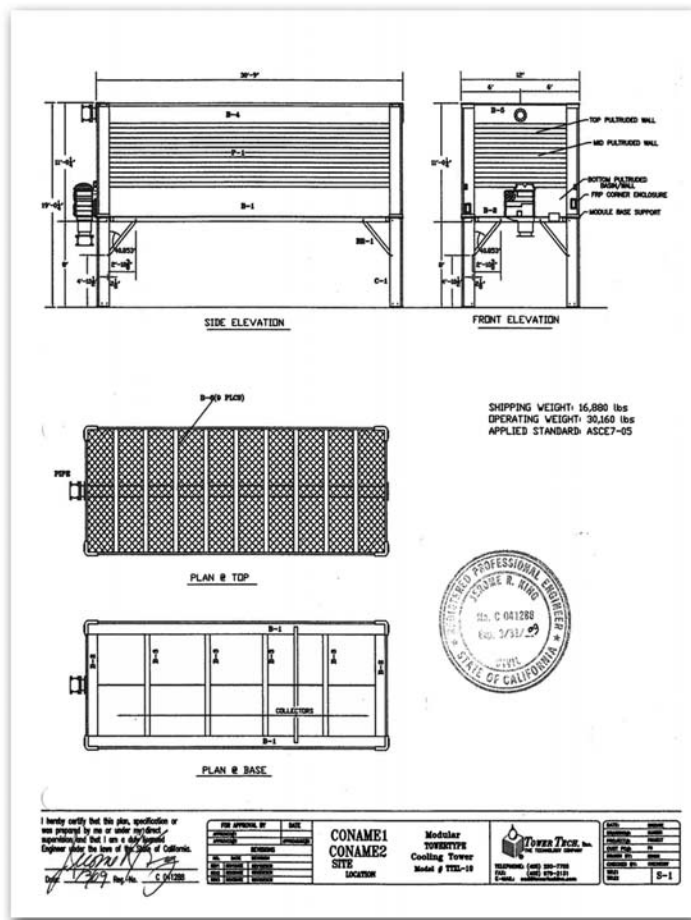

J.R. KING ENGINEERING
 10890 NORTHMARK DRIVE
 EDEN PRAIRIE, MN 55344
 952 944-1391
 952 944-0588 (FAX)

Title:
 Fiberglass modular cooling tower – TTXL-10

Purpose:
 Analyze and design the components of the fiberglass cooling tower.

References:

1. AISC, Steel Construction Manual, 8th edition
2. Structural Engineering Handbook, 2nd edition
 By Gaylord & Gaylord, 1973 McGraw-Hill
3. Aluminum Structures, 2nd edition
 By J. Randolph Kissell & Robert Ferry
4. Risa3d – Rapid interactive structural analysis,
 three dimensional, computer software

Specifications:

1. Tower Tech tests and material properties data
2. Creative Pultrusions, Inc. material properties data

Design Requirements:
 The design loads shall be in accordance with the IBC (International Building Code). Wind, seismic and gravity loadings are applied. The illustrated tower shell and substructure is designed to withstand a wind pressure of 41 psf (ASCE7-05 150 mph wind, exposure C) and a seismic force factor: $C_s = .4 \times$ weight, category D ($S_s = 200$, $S_1 = 150$, soil class E).

Procedures:
 Procedures are the methodologies indicated in the listed references, as specifically presented within the calculations. To use the AISC equations and built-in sections within risa3d, the fiberglass properties have been put in place of the steel; the printouts that have "Steel" headings are calculated as fiberglass and should be interpreted as such. The properties of the fill material are based on actual in-house tests. Safety factors are calculated and compared to those for steel, aluminum, and wood.

Conclusions:
 The analysis and design of the subject cooling tower and their appurtenances have been completed satisfactorily.

The thermal performance of the TTXL Series cooling towers is certified by the Cooling Technology Institute in accordance with its standard STD-201 and has been assigned CTI certification validation number 08-17-06. This certification is your assurance that the proposed capacities accurately reflect actual cooling tower performance. CTI certification under STD-201 is limited to thermal operating conditions with entering wet bulbs between 55°F and 90°F (12.8°C and 32.2°C), a maximum process fluid temperature of 125°F (51.7°C), a cooling range of 4°F (2.2°C) or greater, and a cooling approach of 5°F (2.8°C) or greater.



Our vision is to be the most customer-driven cooling tower company in the world -- the standard by which all other cooling tower companies are measured.

We are committed to preserving and protecting the environment by leading our industry in water and energy conservation and environmental responsibility.



5400 N.W. 5th St., Oklahoma City, OK 73127

TEL 405.290.7788 • FAX 405.979.2131

www.TowerTechInc.com